



*How to sew
with your new*

VIKING

Husqvarna

6000 Series

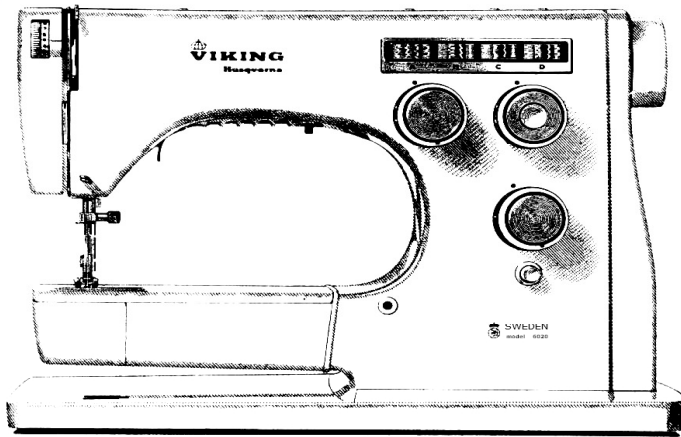

*Here's to many
happy hours with
your new sewing
machine!*

You are now the owner of one of the most modern and easy-to-use sewing machines on the market. It is our sincere wish that your new Viking will come up to all your expectations and will give you service for many years.

This booklet is presented in order to help you get the most out of many pleasant hours with your machine. Wishing you every success with your new Viking 6000 Series —

In countries other than the USA and the UK, the Viking 6000 Series is sold under the name of Husqvarna 2000. Technically the machines are identical and for practical reasons the illustrations in the manual show the Husqvarna 2000.



**HUSQVARNA
VAPENFABRIKS
AKTIEBOLAG
HUSKVARNA — SWEDEN**

TABLE OF CONTENTS

	Pages
Accessory box, contents	43, 44
Blind stitching	24
Blindstitching plate	24
Bobbin and bobbin case	6
Bobbin winding	5, 6
Buttonholes	28—32
Buttonholes, reinforced	30, 31
Buttons, sewing on	32, 33
Care of the machine	49—50
Darning with darning foot	41—42
Edge guide	17
Elastic blindstitch	25
Elastic straight stitch	25
Extension plate	3
Extra accessories	45—48
Fault finding	51
Feed dog, lowering	33
Foot control	10
Foot control, connecting	2
General view of the machine	52
Hemmers	35
Lighting	3, 4, 50
Lower thread, bringing up	8
Lower thread, checking	4, 5
Lower thread, tension	15, 16
Lower thread, threading	6, 7
Machine, putting away	11
Needle and thread	12, 13
Needle, changing	13
Overcasting	22
Overcasting of terry cloth, jersey	23
Pattern stitching	26, 27
Presser foot, changing	17, 18
Presser foot, pressure	40
Quick-mend	36—39
Raised seams	34
Reduction gear	10
Releasing presser foot pressure	40
Reverse stitching	17
Seam former	26
Stitch length knob	9, 16
Stitch width knob	9, 21
Stitch selector	9, 21
Straight stitching	16
Tape method of attaching zippers	20
Thread	12, 13
Thread cutter	9
Thread tension	14, 22
Three-step zig-zag	23
Unpacking machine	2
Upper thread, tension	14
Upper thread, threading	7, 8
Zig-zag stitching	21
Zipper fastening	18, 19

We reserve the right to change at any time the design or the equipment.



Unpacking the machine

Start by putting the piece of foam plastic on the sewing table and by placing the sewing machine on this piece. Then remove the accessory box by lifting it somewhat upward and drawing it out along the length of the machine.

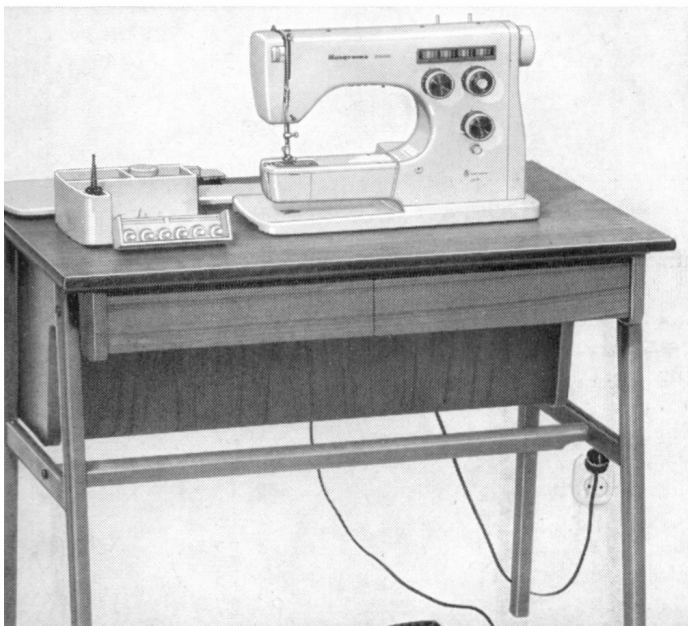

Connecting the foot control and power cord

Take the foot control out of the accessory box and set it in place under the sewing table. Insert the foot control plug into the socket at the back of the machine. See that the cord runs over the rear edge of the table. *Before plugging in, see that the mains voltage is the same as that of the machine.* The machine's voltage is given on a plate at the back of the machine.

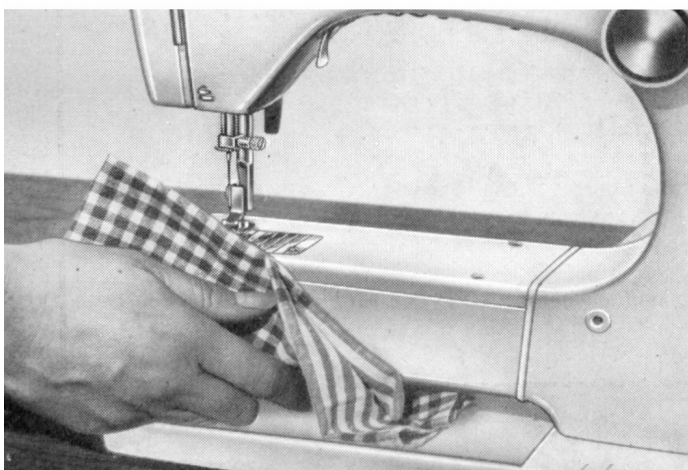
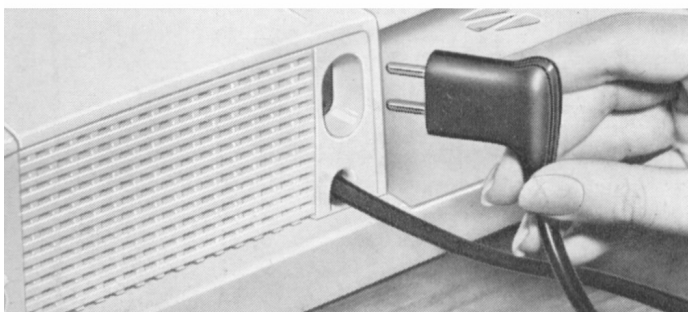

Wiping off the machine

The sewing machine has been oiled liberally during manufacture and in spite of careful cleaning surplus oil may still remain on the machine. Take a soft cloth and wipe around the needle and the free arm. Sew back and forth several times on a scrap of material before you begin sewing a garment.

Attaching the extension plate

Pull out the catch on the back of the extension plate with the index finger of your right hand. Then grasp the extension plate support with your left hand and turn it down.

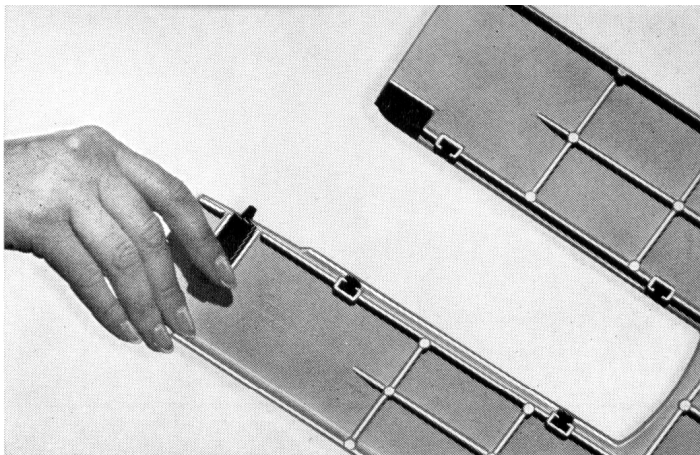

There is also an indentation on the back of the extension plate which should be fitted into a corresponding lip on the back of the sewing machine.

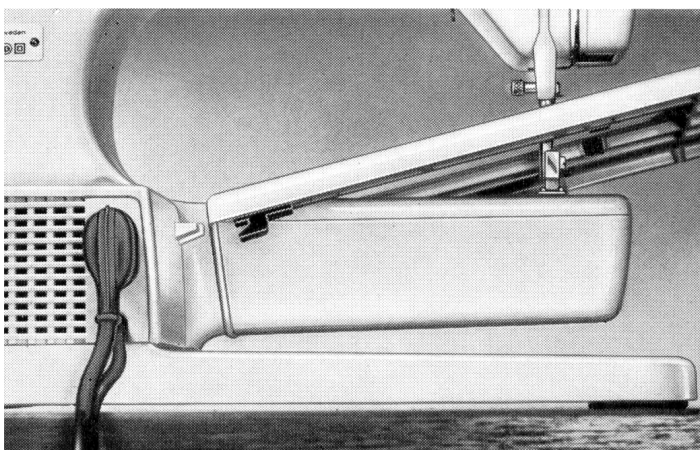

Keep the catch pulled out while you carefully slide the plate onto the machine. First fit the indentation onto the lip and then let the catch engage in its hole.

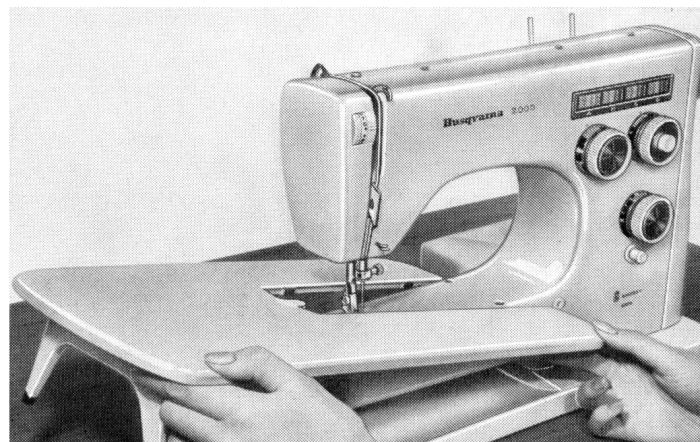

Lighting

The light switch for the lamp is on the underside of the machine's upper arm.





Lighting

(continued)

There is a projection which may be used to lower the lamp on the left side of the lamp guard. This is good for hand sewing, threading the needle or for detail work. To change the light bulb, see the chapter "Care of the Machine".

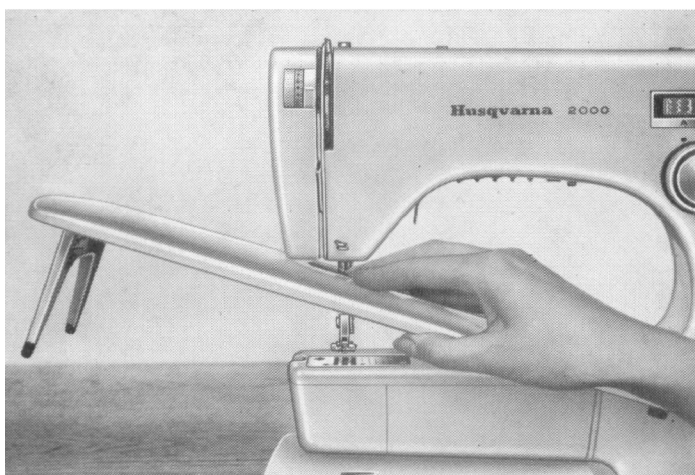

Checking the lower thread

The picture shows you how to lift the extension plate in order to be able to open the shuttle door and make sure that there is thread on the bobbin. Until you are completely familiar with the machine, it may be simpler to remove the extension plate.



There is a small recess on the free arm to facilitate the opening of the shuttle door.

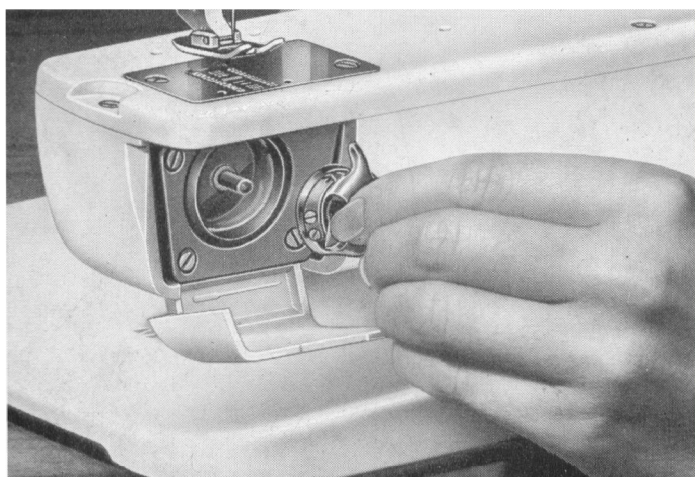

Grasp the bobbin case with the thumb and index finger so that the latch is depressed and draw out the bobbin case. The bobbin will remain in the case as long as the latch is depressed. When you release the catch, the bobbin will be released.

If there is sufficient thread on the bobbin, replace the case with the "arrow head point" in the recess on the gripper plate. Close the shuttle door.



Bobbin winding

Take an empty bobbin from the accessory box. Slide it onto the bobbin spindle which is located on the side of the machine. Place the thread over the bobbin. Wind the thread around the bobbin several times. Hold the end of the thread while you press down the foot control. Release the end as soon as winding starts. Stop winding before the bobbin is completely filled — about 1/32" (1 mm) from the edge.

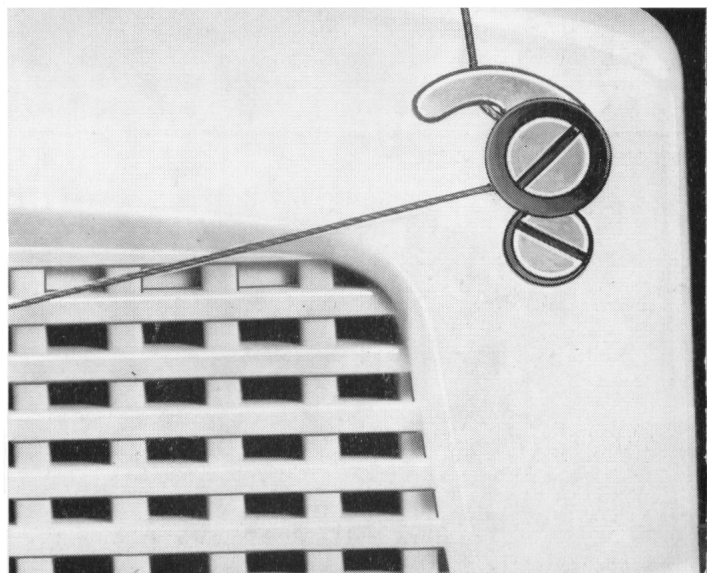
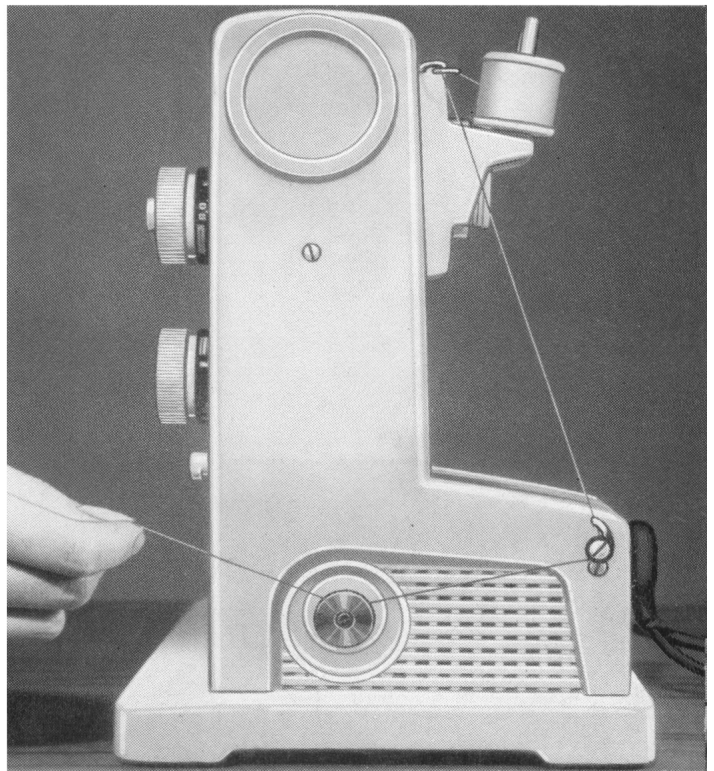

Bobbin winding

(continued)

If you notice that the bobbin is winding unevenly as in Figure I, turn the thread tension device clockwise with the aid of the heavier screwdriver until the winding becomes even.

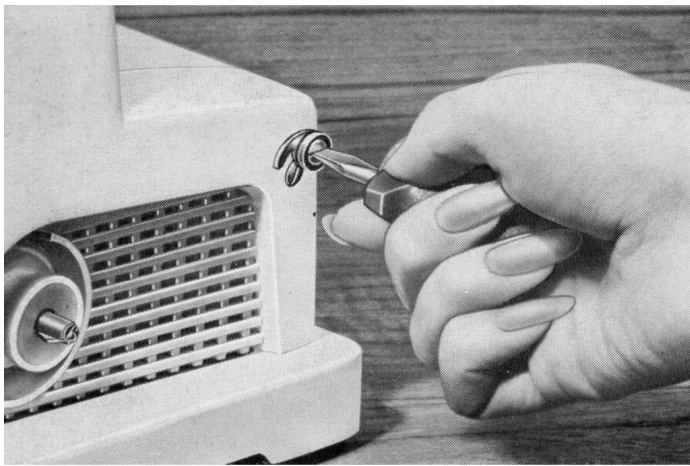
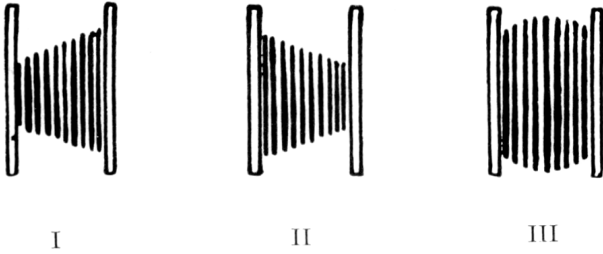

If the winding looks like Figure II, check to see if the bobbin is properly pressed in on the spindle. If this is correct, turn the thread tension device counter-clockwise until the winding becomes even. Figure III shows a correctly wound bobbin.

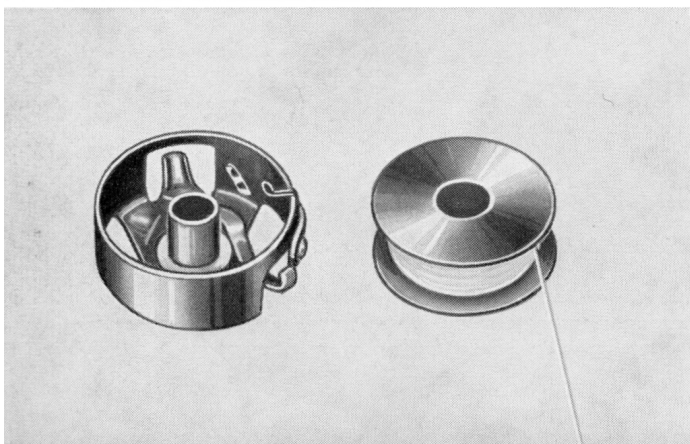

Bobbin and bobbin case

When the bobbin is wound, place it beside its case. Notice which way the thread runs. Place the bobbin in its case without turning it around.

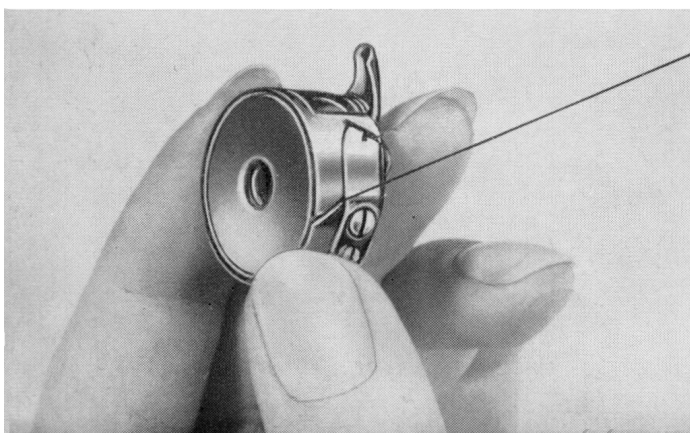

Threading the lower thread

Slide the thread into the slot on the edge of the bobbin case.

The thread is pulled in under the tension spring. Also check that the bobbin rotates in the direction of the arrow when the thread is pulled.

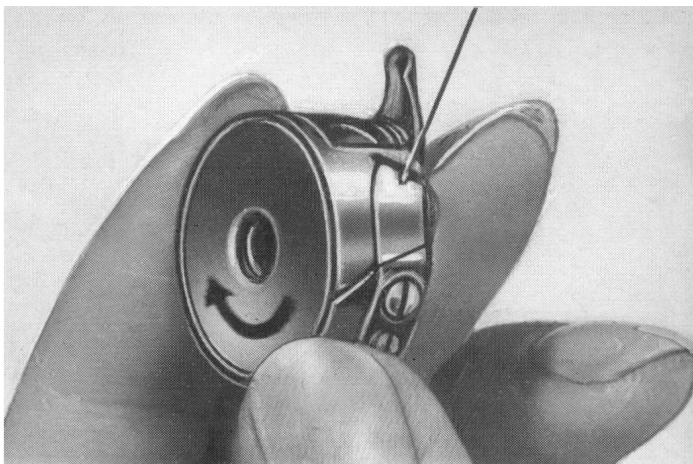

Threading the upper thread

In the accessory box you will find a spool of thread which was used to test your machine. More details about thread are to be found in the chapter "Do you have the right thread?" Make sure that the presser foot is raised. Place the spool of thread on the left-hand spool pin and thread for sewing.

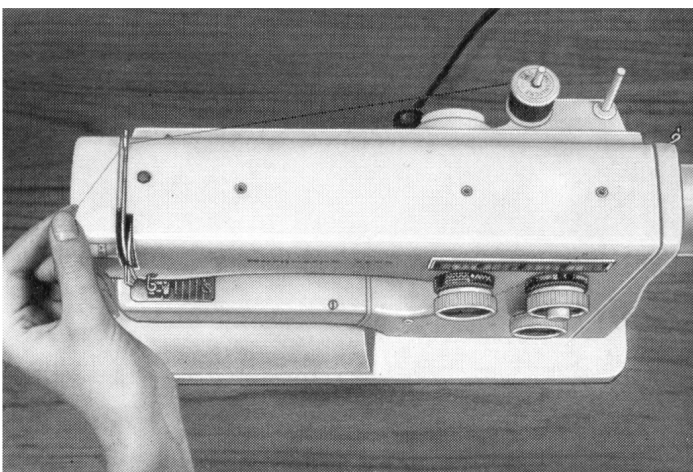

Place the thread in the thread guide on the "upper arm". Then draw the thread to the left and down around the thread guide.



Now continue threading by drawing the thread through one of the eyes of the thread take up lever. Then pull the thread through the thread guide coil.

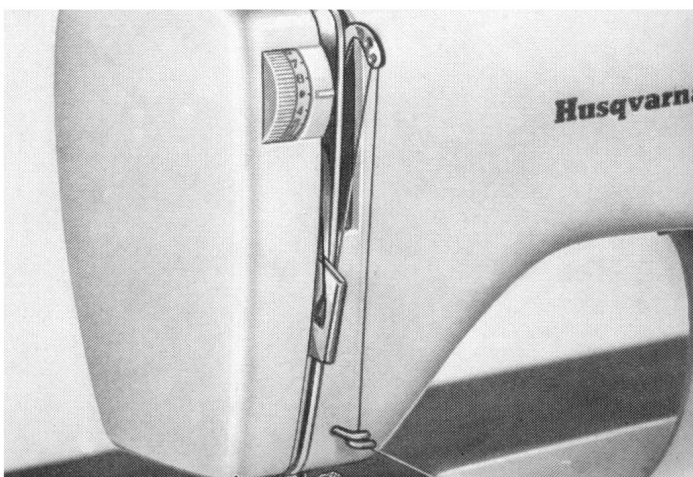

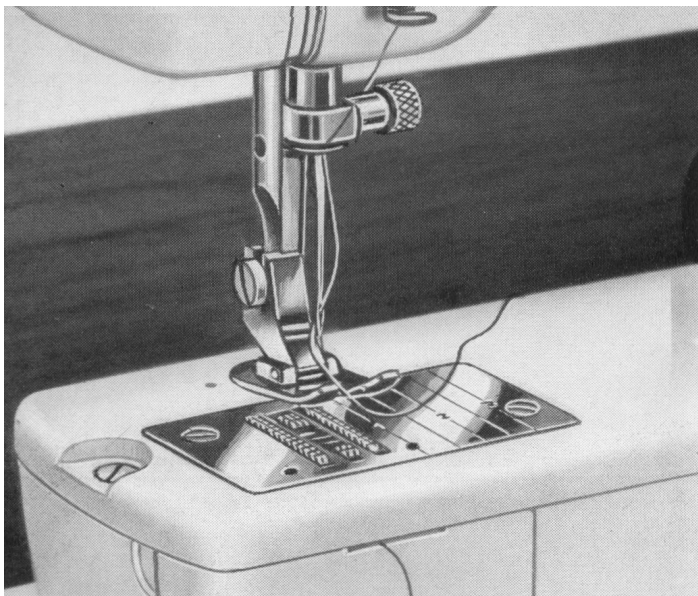

Threading the upper thread

(continued)

Be very careful to see that the thread actually lies behind the black thread guide up on the needle bar. Thread the needle from the front.



Bringing up the lower thread

Be sure that the lower thread runs up through the slot in the shuttle door. The lower thread is brought up by turning the hand wheel toward you until the needle goes down and then up again. Then pull the upper thread carefully toward you and the loop which draws up the lower thread is easily caught. Do not pull the thread before the needle has returned to its highest position. Neither should you pull the upper thread too hard as this may bend the needle.

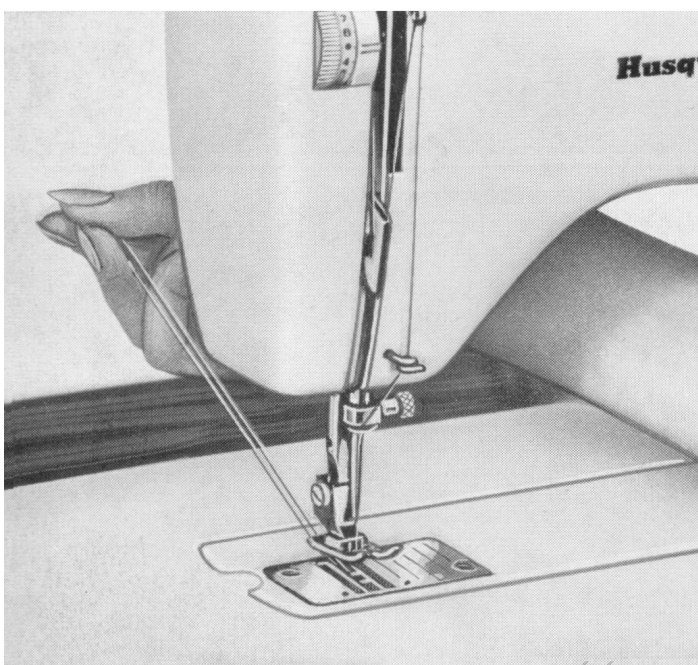

Pull the threads about 6" (15 cm.) toward the rear. If the thread ends are too short, the thread may glide out of the eye of the needle when you begin to sew. Now you can replace the extension plate.

Thread cutter

On the back of the presser bar you will find a notch, the thread cutter, which makes it easy for you to cut off the threads.

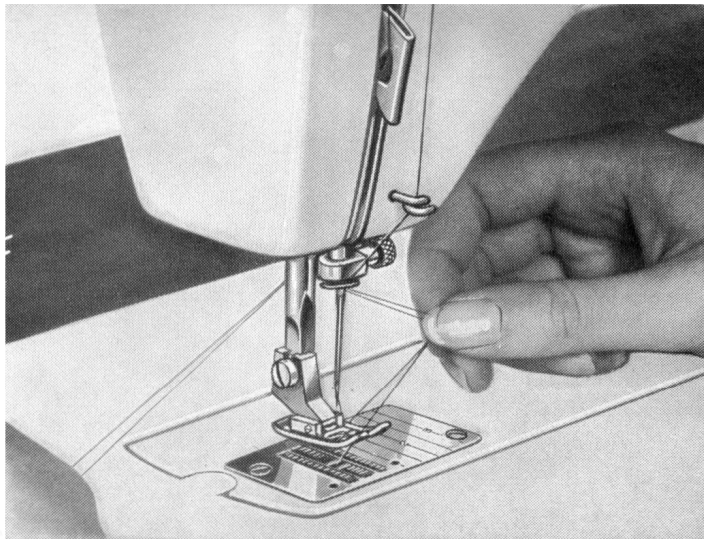

You can now begin sewing

On the right side of the machine you will find the adjusting knobs for different types of stitching. The upper left knob is the stitch selector by means of which you can choose the stitch you require in accordance with the symbols marked on it. The upper right knob adjusts the stitch length. This knob is graduated from 0 to 4. The micro-graduations between 0 and 0.5 permit precision adjustment. The lower knob adjusts the stitch width from 0 to 4.



We begin by sewing a straight stitch which is the seam most frequently used. The sewing machine is adjusted for straight stitching when it leaves the factory but for the sake of certainty, check that the knobs are set as shown on the picture.

Normal stitch length is abt. 2 and the stitch width knob should be set on 0 for straight stitching.

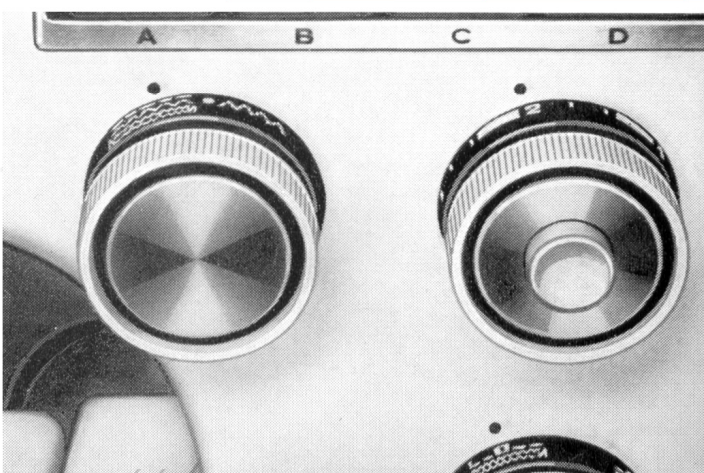

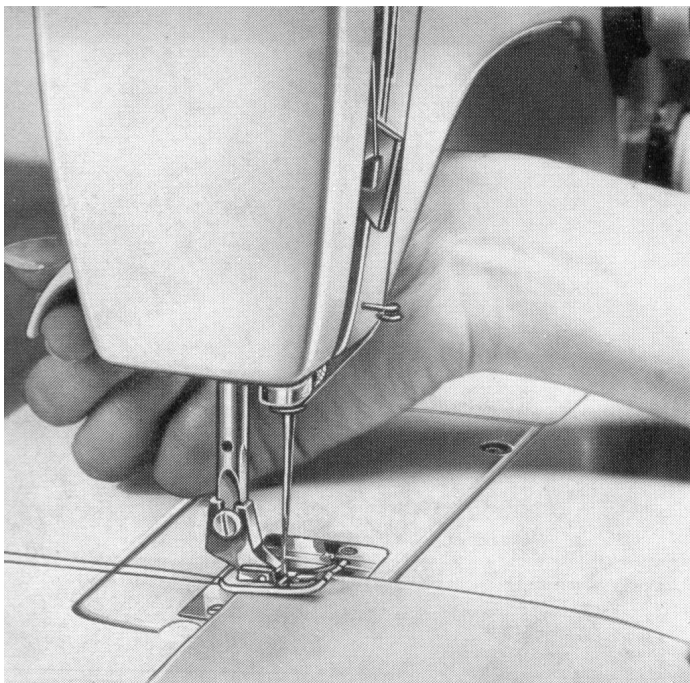

You can now begin sewing

(continued)

The picture shows how to begin about $\frac{1}{4}$ " (1—2 mm) in from the edge of the fabric in order to prevent it from being drawn into the needle hole. Lower the presser foot. Always begin sewing with the needle down in the fabric and finish with the needle up out of the fabric. This prevents the needle from being bent or broken.



Foot control

Place the foot control so that the foot rests on it comfortably. Low-heeled shoes are most suitable. Start the machine by gently pressing down the foot control. Remember that you never need to assist or brake the machine with the hand wheel while sewing. The speed of the machine is regulated solely by increasing or releasing pressure on the foot control. Neither should you try to increase the feeding by pulling the fabric behind the needle or slow it down by pulling the fabric in front of the needle. The foot control may perhaps become slightly warm during use. This is not a cause for worry since the resistor which is built into the foot control gives off heat, especially at low speeds.

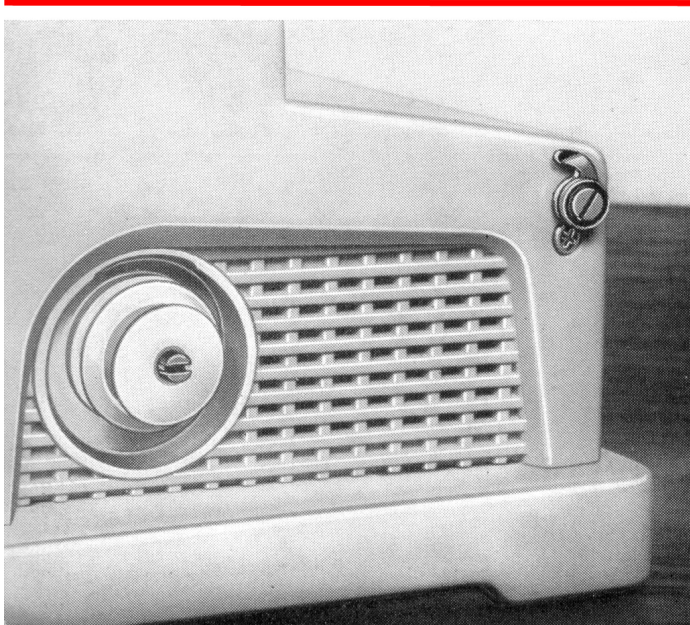

Reduction gear

or the low gear, as it is also called, is one of the many practical features with which your machine is equipped. If you grasp the little wheel which is located inside the bobbin spindle and pull it outward, the machine will sew only $\frac{1}{5}$ as fast as usual. Try it and see. This low speed is of advantage if you wish to sew slowly stitch by stitch, for example when monogramming or embroidering.

Putting the machine away

Pull out the foot control plug. Wind the cord around your hand, starting at the control. Press the foot control together and place it in its compartment with the thick end down. The bottom of the foot control should be turned toward the machine and hold the cord in place beside the foot control in the compartment.



Wind the cord from the machine toward the plug and put the plastic cord band around the cord.

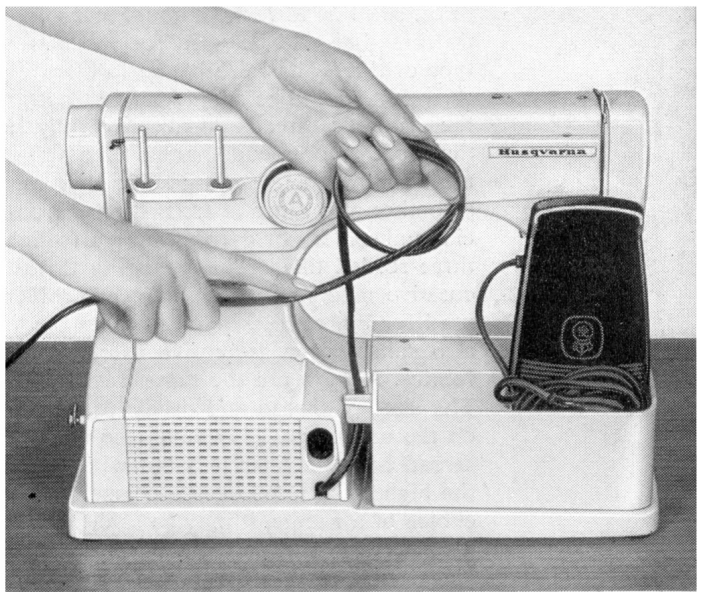

Lower the presser foot. Slide the accessory box into place and see that the machine cord goes behind the edge of the accessory box, and put the cord in the box.

Then lift the machine into the case. Place the extension plate inside the case-lid and the piece of foam plastic as protection between the sewing machine and the extension plate. The instruction book may be placed behind the extension plate.



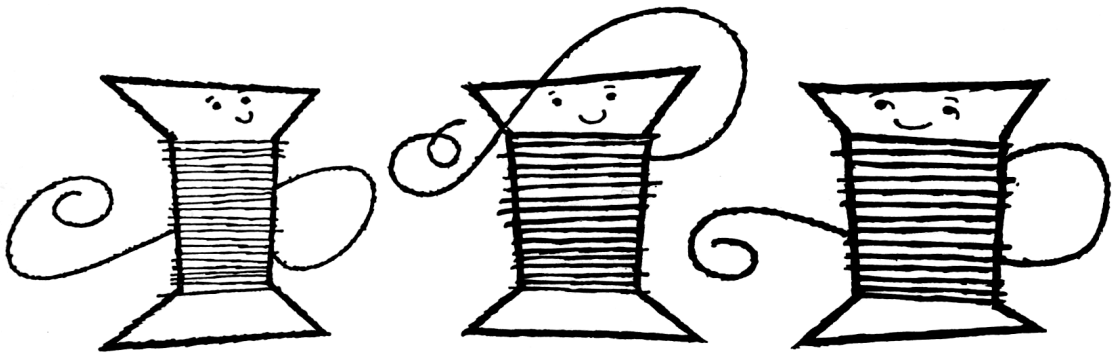

Do you have the right thread?

To obtain the best sewing results, it is very important to use the correct thread and needle for the fabric to be sewn. An old rule says that you should use cotton thread for cotton and linen fabrics, silk thread for silk and woolen fabrics. Accordingly, synthetic thread should be used for the new synthetic fabrics and this type of thread has also begun to be available. If you use synthetic thread, it should be spun thread but at present it must be said that the synthetic threads do not give fully satisfactory results and we therefore recommend the use of cotton thread. All cotton thread used for machine sewing should be mercerized. It is softer and smoother also more lustrous than the unmercerized thread. A special embroidery or darning thread (which is two-corded instead of three-corded like ordinary sewing thread) should be used for decorative stitching. If possible, embroidery thread should also be used for buttonholes (No. 50 gives the very best results) and it is also suitable for decorative stitching and overcasting very sheer fabrics. Always use the same thread for upper and lower threads. The sizes of thread and needle to be used are shown on the table on the next page. This table also shows that the higher number a thread has, the finer it is but with needles it is just the opposite: the higher the number, the coarser the needle. With regard to the choice of a needle, it may be said that No. 80 is a general-purpose needle which can be used for most fabrics but for sheerer fabrics and finer thread, a finer needle should also be used. The primary reason for choosing a finer needle for sheer and tightly woven fabrics is that the threads in the weave are damaged by a coarse needle. Obviously, a coarse needle which will withstand the greater strain must be used for very heavy and stiff fabrics.

Choice of needle

You will find a picture of a needle on the inside of the shuttle door. The needle system has number 705. The machine is fitted with needle No. 80. You will also find a number of extra needles of various sizes in the accessory box.

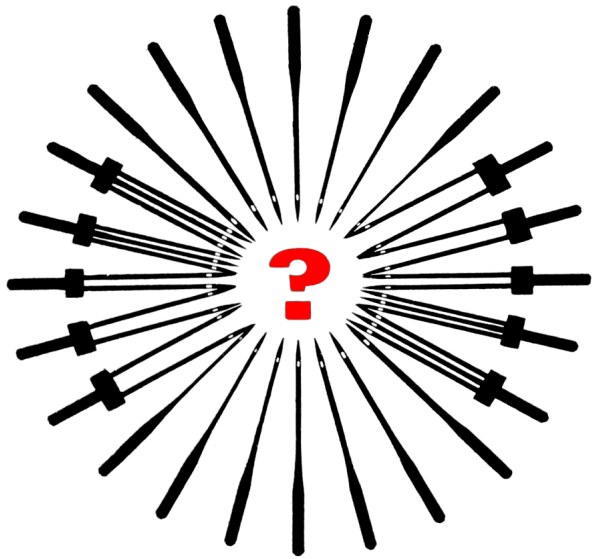

Changing the needle

Loosen the needle clamp screw and remove the needle which is to be changed. The flank of the needle has a flat side — turn it away from you and push the needle up into the needle socket. It should be inserted as far as the built in stop. Tighten the screw and the needle is held firmly.

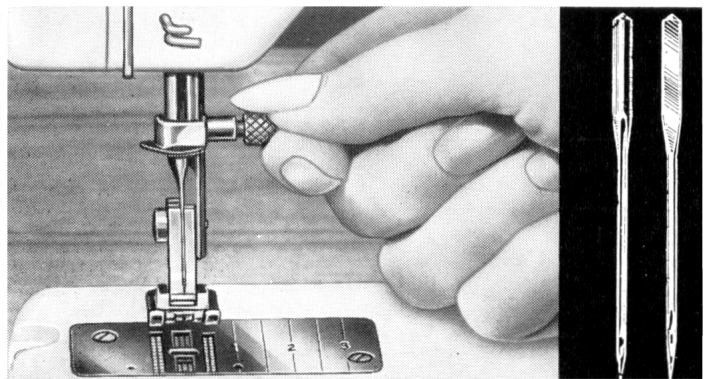
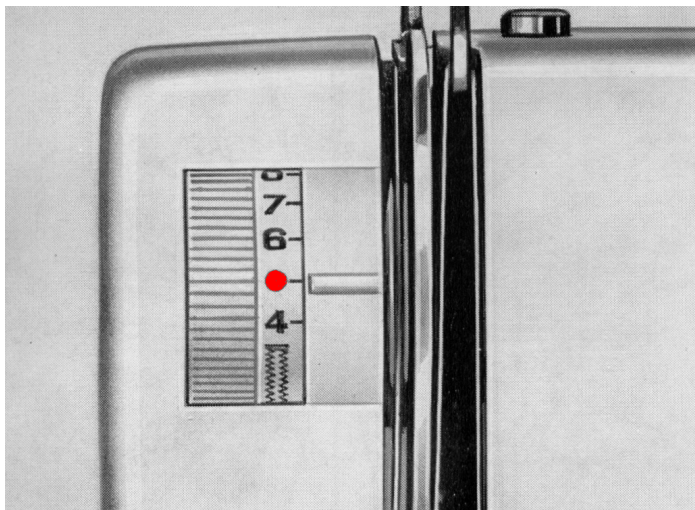

Table for selecting needle and thread

	Sewing thread English No.	Coloured sewing thread No.	Silk thread	Embroidery thread or Darning thread	Needle No.
Delicate fabrics such as fine silk and linen, batiste voile, organdie, tulle and sheer nylon fabrics	60—			60—	70
Light-weight to medium fabrics — poplin, piqué taffeta, woollens, muslin, plastic and heavy nylon fabrics	50—60	26	100/3	40—50	80
Medium-weight fabrics, sheeting, cotton twill, velveteen, light-weight draperies, jersey and thin leather	40—50	26	100/3	30—50	90
Heavy fabrics — heavy woollens and suiting, heavy sheeting and woven plastic material	40			20	100
Very heavy stiff fabrics, such as wind-proofed material and khaki drill	30				110
Extra heavy work					120

The above table shows combination of needle and thread which are most suitable in each particular case.



Tension of upper thread

It is very important to have the correct thread tension when sewing. You can see the knob which regulates the tension in the picture at the left. It is graduated from 0 to 10 and equipped with a stop. Normal thread tension is obtained by setting the pointer at the red spot. Your machine has been tested with the thread which accompanies it and with the thread tension knob set at the red spot. It may be necessary to adjust the thread tension somewhat if you use thread of another thickness.

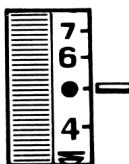
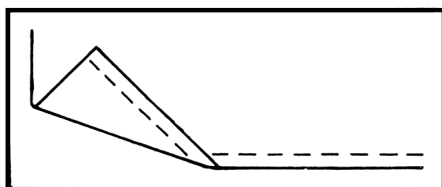
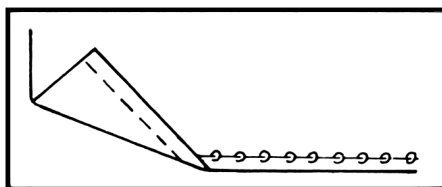
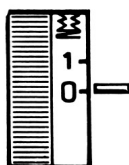
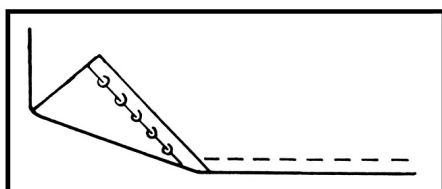

In order to easily understand the importance of correct thread tension, you can try different thread tensions by sewing on a scrap of cloth. Begin by using an excessively loose tension, i.e., you turn the thread tension knob upwards as far it will go. Look at the cloth and you will find the lower thread lies straight and the upper thread is drawn down into the lower side. If you turn the knob downward, the opposite occurs. The upper thread lies straight and the lower thread comes up in loops on the top of the cloth.

The thread tension is correct when the threads interlock in the middle of the layer of material. Before starting to sew, check the tension by sewing on a piece of the same fabric you intend to work with.

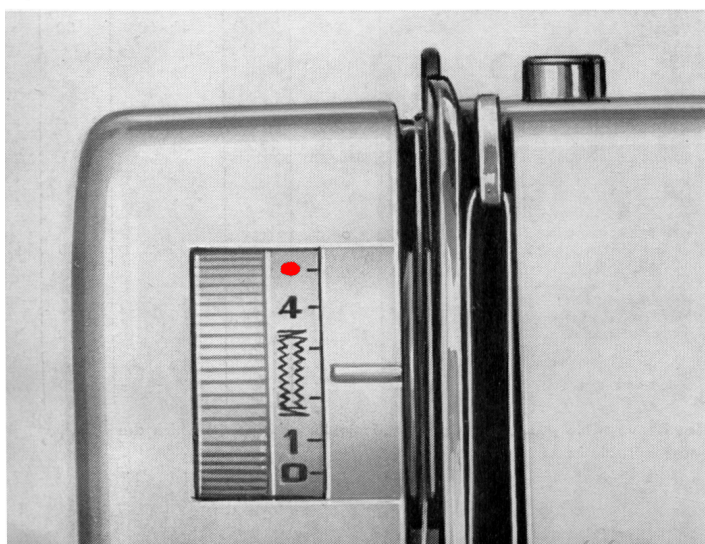

There is also a special mark on the thread tension knob for the tension to be used for making buttonholes. This is also most suitable for close pattern stitching, monogramming, embroidering, etc.

Tension of lower thread

In most cases of incorrect thread tension, it is sufficient to regulate the tension of the upper thread, but if this is insufficient, proceed as follows:

Open the door on the free arm and remove the bobbin case. Take out the bobbin and clean the case from dust, etc. Check that no fluff or lint has collected under the tension spring and is causing the trouble.

Then place the bobbin case on the left and the bobbin to the right, noticing how the thread runs.

Insert the thread into the slot on the side of the bobbin case.

Draw the thread in under the tension spring. Check that the bobbin moves in the direction shown by the arrow by drawing on the thread.

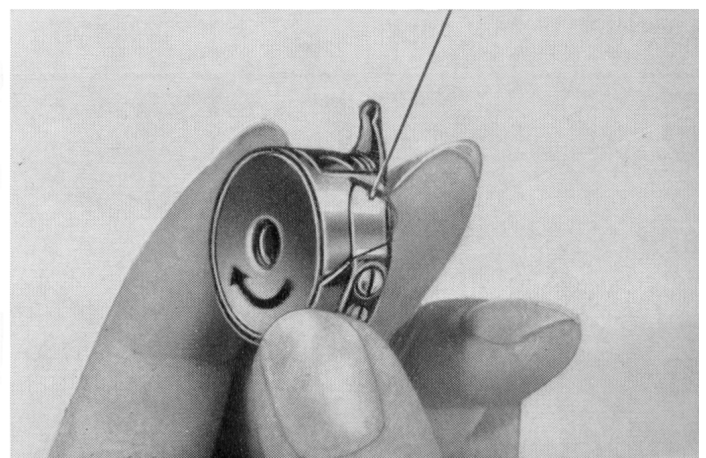
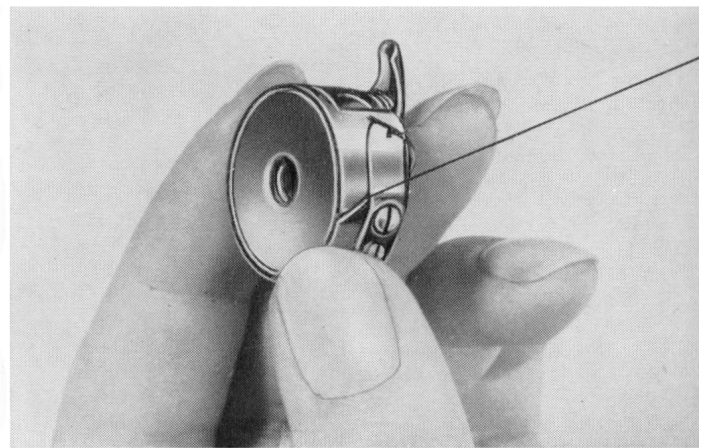
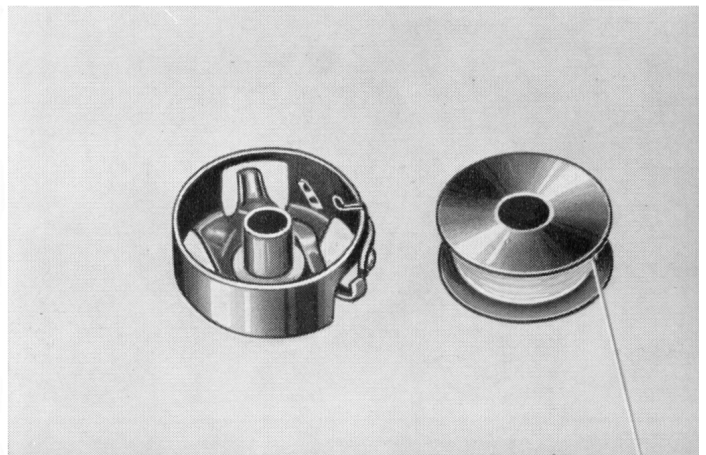
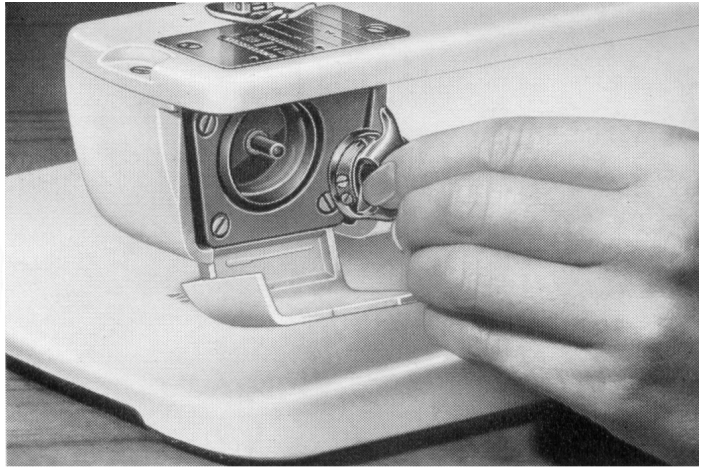

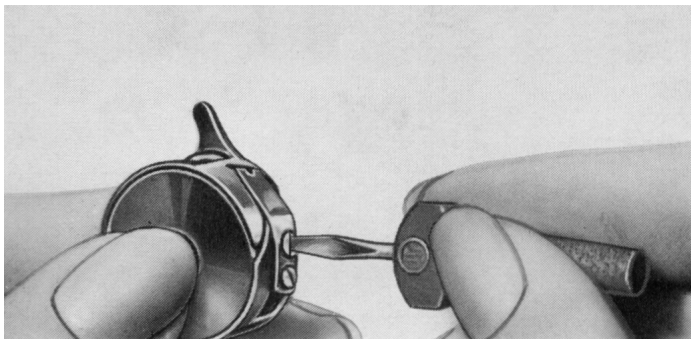

Tension of lower thread

(continued)

If it is necessary to adjust the tension of the lower thread, take out the small screwdriver from the accessory box. Fit it in the larger screw on the tension spring and turn it not more than 1/10th of a turn to the left if the thread tension is too hard, to the right if it is too loose.



Set the bobbin case in place with the projection straight up. Press the bobbin case slightly so that it comes into the correct position. Shut the shuttle door.

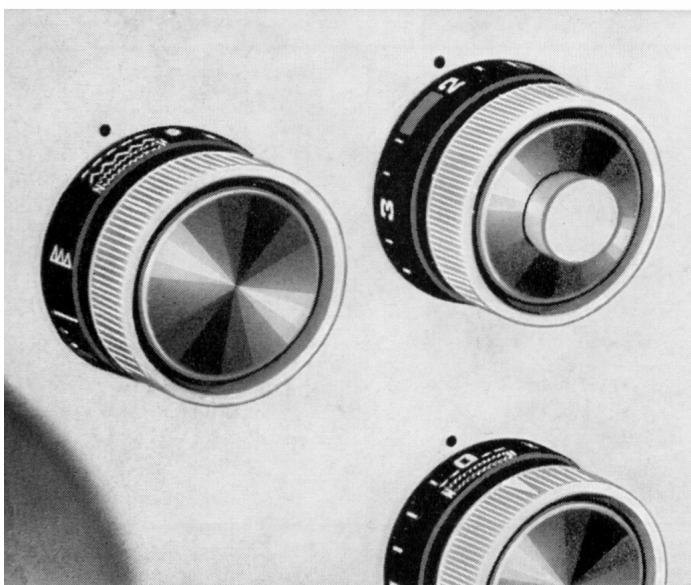

Straight stitching

This is the most usual type of stitching and no doubt you have already done quite a lot of this when test-sewing. Set the machine as follows: Set the left-hand knob — the stitch selector — to the straight stitching symbol. Set the right-hand knob — the stitch length knob — which is graduated from 0 to 4, for the desired length of stitch, normally 2. The lower knob — the stitch width knob — should be set at 0 for straight stitching.

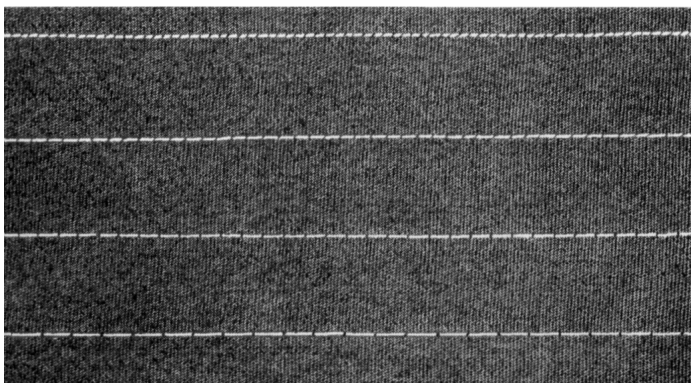

The picture shows straight stitching with different stitch lengths.

Reverse stitching

In the centre of the stitch length knob there is a button intended for reverse stitching. By pressing in this button the machine will run in reverse, but will resume normal stitching as soon as it is released. This is very useful when, for example, finishing off a seam.

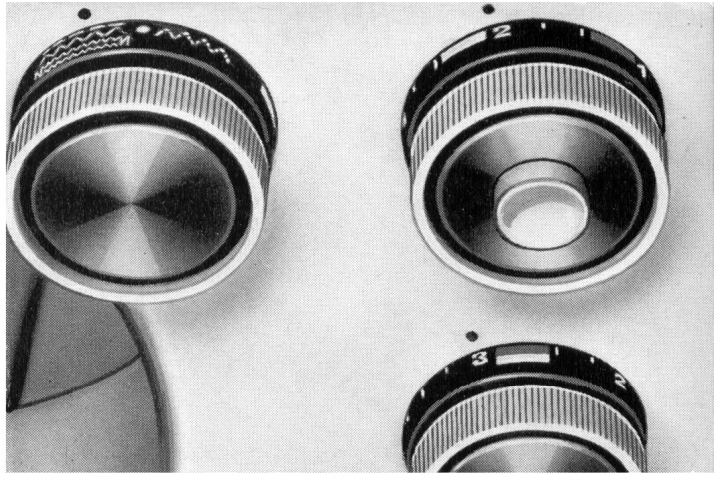

Presser foot for straight stitching and zigzag stitching

The presser foot which is fitted on the machine at delivery is used for straight stitching, zigzag stitching and a number of other stitches. As you can see, it has different notches which can be used as guides when sewing. If you wish to have a seam allowance about $\frac{1}{4}$ " (7 mm.), let the material run even with the outer edge of the presser foot. By moving one step inwards, you will have a seam allowance of about $\frac{5}{32}$ " (4 mm.). The innermost notch gives a seam allowance of about $\frac{5}{64}$ " (2 mm.).

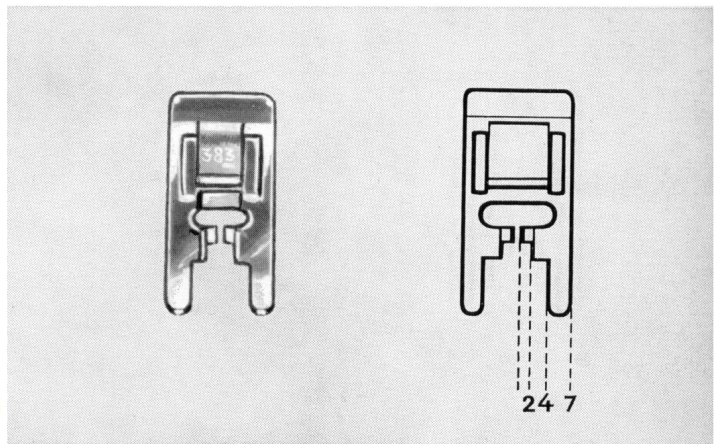

Edge guide

You can easily sew with wider seam allowances with the aid of the edge guide which you will find in the accessory box. The edge guide is inserted through the hole in the presser bar and is secured to the bar by means of an attachment screw which is found in the accessory box.

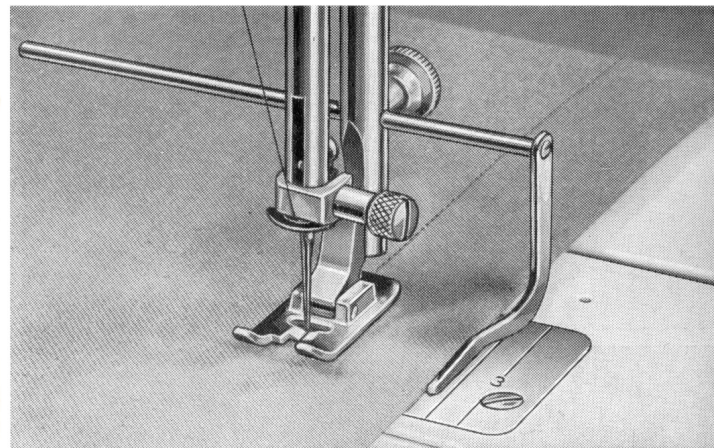

Changing the presser foot

Most of the presser feet which accompany the machine have the form of loose soles which are held in place on the presser foot by a spring. If you wish to change the presser foot, first make sure that the needle is in the highest position. (Turn the hand wheel toward you.) Remove the presser foot by drawing it toward you while pressing slightly downward.

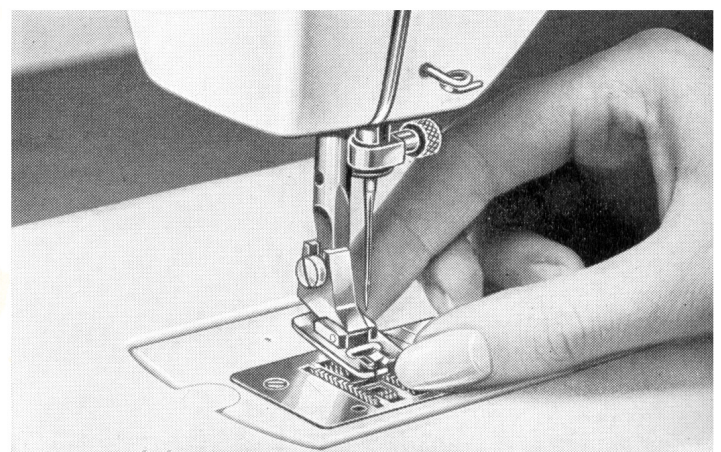

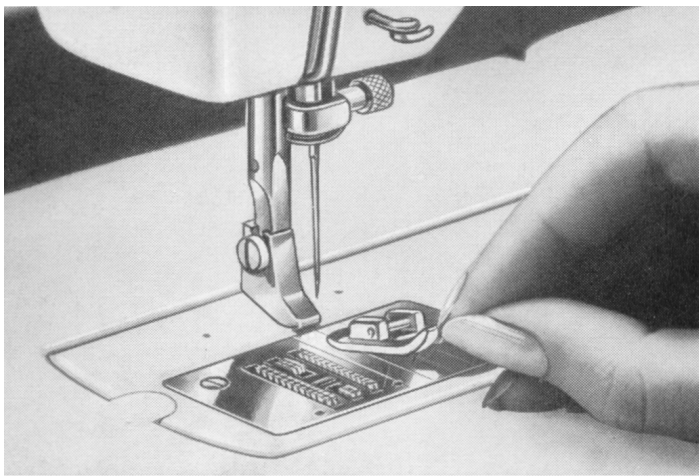

Changing the presser foot

(continued)

Slide the new presser foot over the front edge of the bracket as shown in the illustration. There is a spring on the lower end of the bracket. Slide on the presser foot so that the round transverse pin on the presser foot fits into the space between the bracket and the spring. Then press lightly backward and downward and the presser foot will come into the correct position.

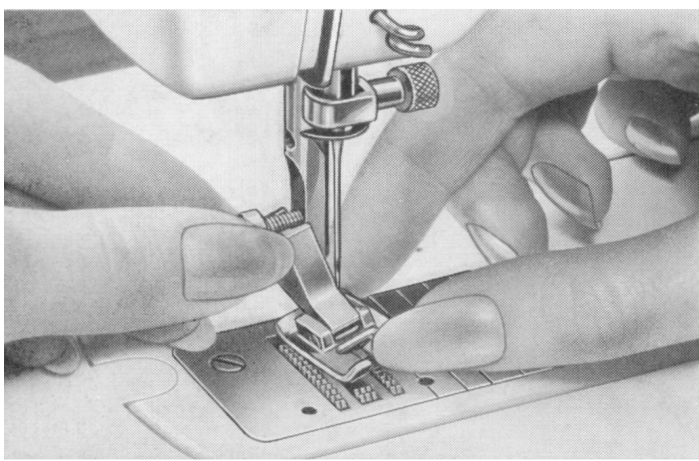

Certain presser feet cannot be constructed as loose soles and then the bracket must also be changed. Make sure that the needle is in its highest position. Then loosen the retaining screw with your left hand (use the screwdriver if it is too tight) and remove the presser foot with your right hand.

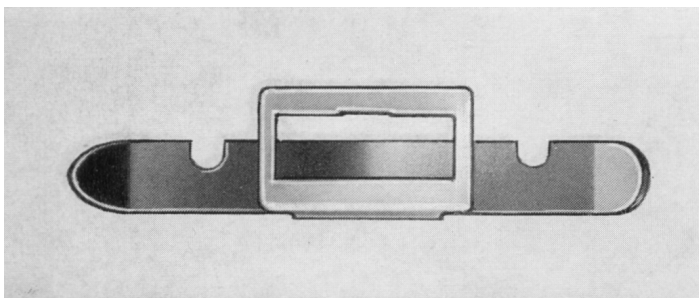

Attaching zip fasteners

Baste the opening together with long stitches and light tension on the upper thread. Leave $\frac{3}{4}$ " (2 cm.) open at the beginning of the opening. Press the seam open and baste the zipper on the underside of the seam.

Set the machine for straight stitching and bring the needle to its highest position. Change to the zipper foot (41 12 989). Turn the presser foot so that it comes to the left of the needle. You attach it in the same way as the ordinary presser foot, see fig.

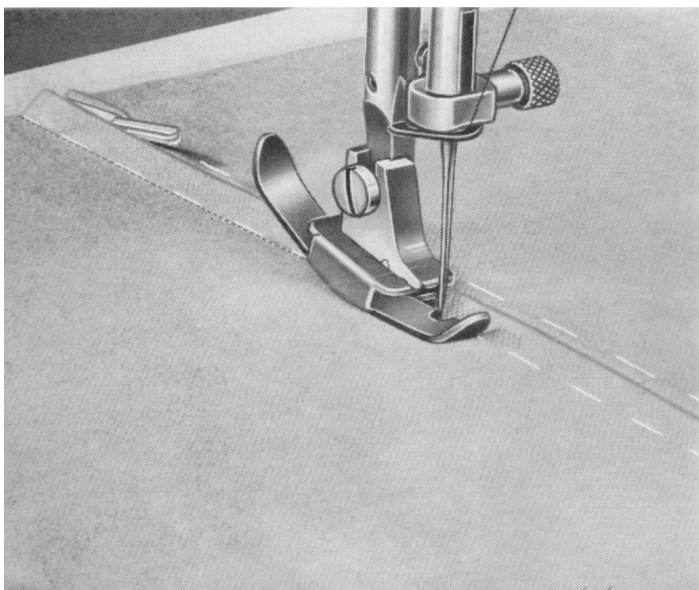

Step 1

Open the zipper about $\frac{3}{4}$ " (2 cm.) and stitch down the left side. Stop with the needle down in the fabric after stitching a bit and lift the presser foot. Close the zipper, lower the presser foot and stitch down to the end of the zipper. Secure the stitching and take the work out of the machine.

Step 2

Bring the needle into its highest position. Turn the presser foot so that it comes to the right of the needle, see fig. Sew the right side in the same way as the left. Finish off with a seam which connects the two long seams. Remove the basting threads.

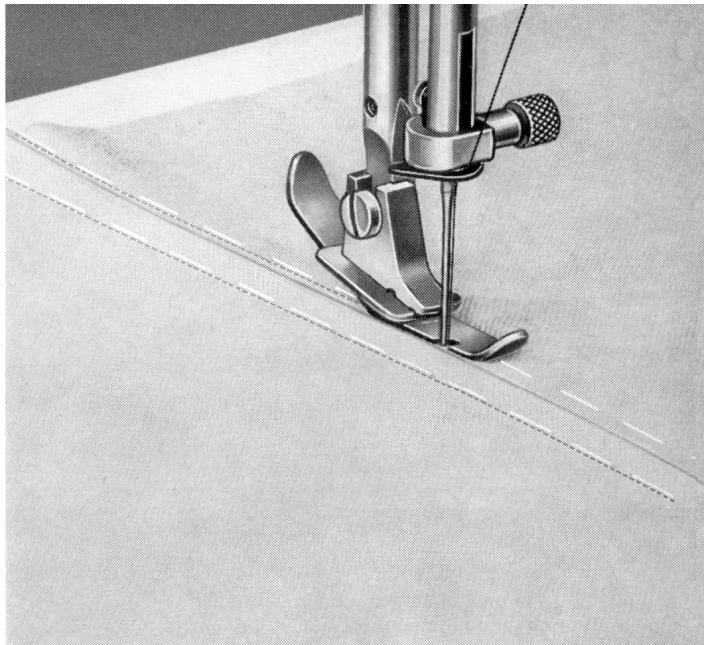

Zipper under front edge of opening

Raise the needle into the highest position. Attach the zipper foot. Turn the presser foot so that it comes to the left of the needle. Baste the opening together with long stitches and light tension on the upper thread. Leave about $\frac{3}{4}$ " (2 cm.) open at the beginning of the opening. Fold the seam allowance on the lower fabric about $\frac{5}{16}$ " (2 mm.) from the basted seam and stitch it to the right edge of the zipper, but turn the work and sew from the bottom up. The zipper should be closed from the beginning but stop sewing with the needle down in the fabric about $\frac{3}{4}$ " (2 cm.) from the end, raise the presser foot and open the zipper so that the slide comes behind the needle. Lower the presser foot and finish sewing.

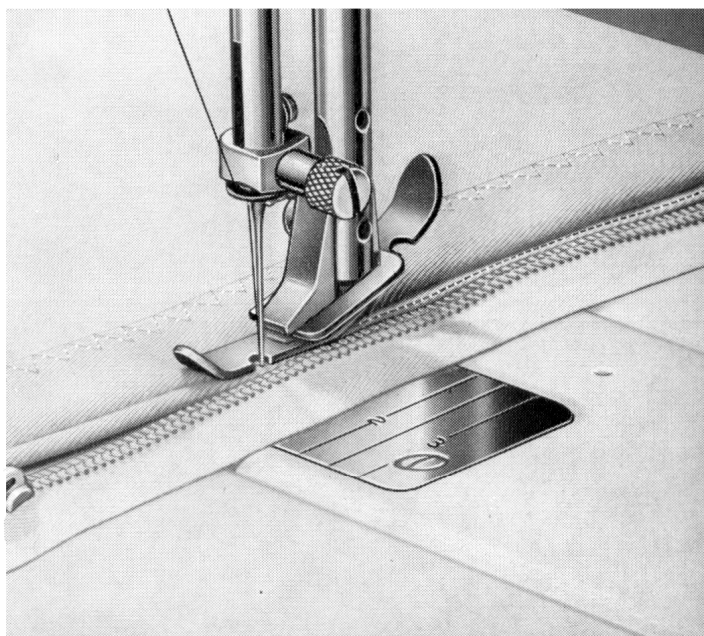

Raise the needle into the highest position. Turn the presser foot so that it comes to the right of the needle, see fig. Turn the garment and stitch the other side of the zipper from the right side. Begin with a seam straight across the lower edge and then stitch from the bottom up. Remove the basting threads.

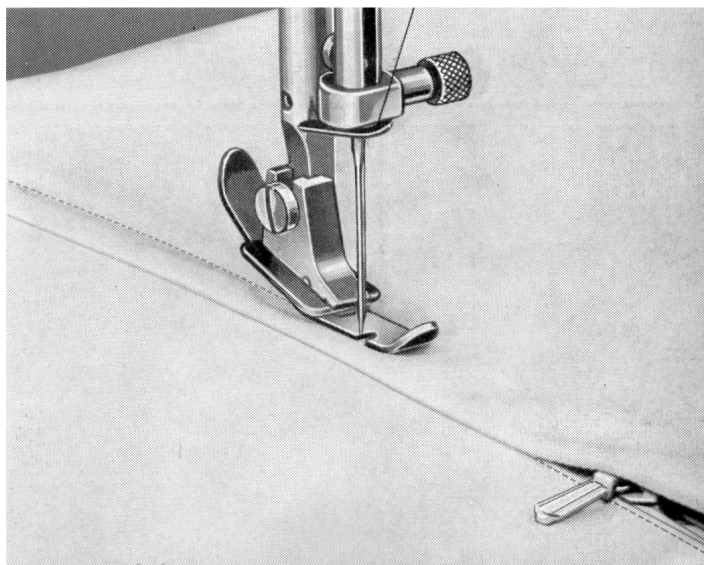

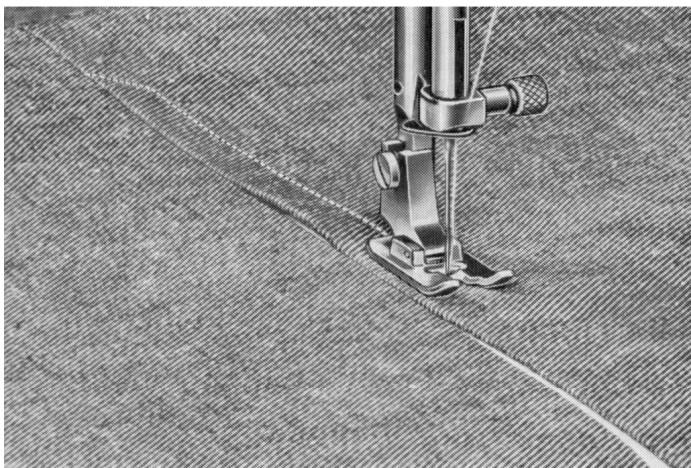

”Tape method” of attaching zippers

Instead of pinbasting the zipper before sewing, you can use tape. The tape should preferably be Scotch Magic Tape, which fastens without being sticky.

You can use the tape-method in almost all kinds of fabrics. However, you ought to be cautious, when it concerns very flimsy or fluffy fabrics. There is a certain risk that only the fluff and not the fabric itself will stick to the tape.

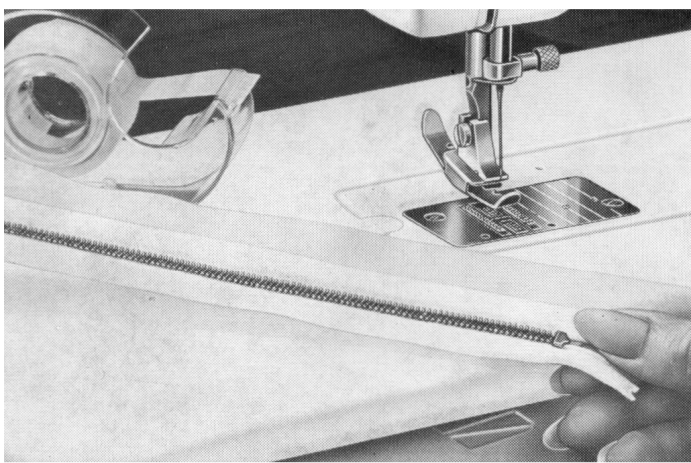

Zipper under front edge of opening

Baste the opening for the zipper together. Press the seam open and remove the basting threads. Make a stitching about 1 cm ($\frac{3}{8}$ ”) wide, from the right side on the left side of the opening.



Change for the zipper foot. Turn the presser foot so that it comes to the left of the needle. Stick a piece of tape to the right cloth edge of the zipper, on the wrong side, so that half the tape edge comes outside.

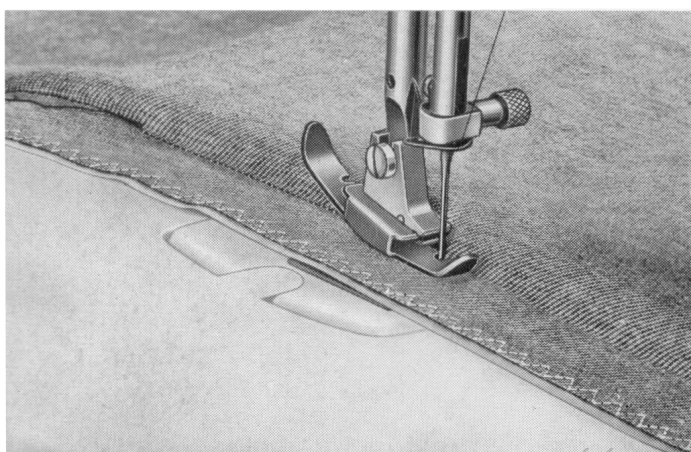

Stick the zipper, by means of the tape, to the side of the opening which is not stitched. Work from the right side. Put the chain of the zipper as close as possible to the folded cloth edge, but still quite visible.

Turn the garment, so that the wrong side comes outside. Turn up the pressed seam allowance. Start sewing from the bottom and don't sew through the tape. Sew on the zipper with a stitching in the pressing. Remove the tape.

Tape together the opening from the right side so that the edges of the opening well cover the chain.

Turn the presser foot so that it comes to the right of the needle. Turn the garment so that the wrong side comes outside again. Fold back the cloth and sew as close as possible to the stitching on the seam allowance. Sew also now from the bottom up.

Stop a few cms. (ins.) from the end of the opening and pull down runner of the zipper, it facilitates the work. Get the stitching ready and attach. Remove the tape and you have now got a beautiful and strong attaching of the zipper.

Zig-zag stitching

When going over to zig-zag stitching, there is one more knob to which you must be introduced — the stitch width knob. Make sure that the stitch selector is set to zig-zag. The stitch width knob is graduated from 0—4. Try out different stitch widths on a piece of material. The stitch width and length can be adjusted while the machine is running. If, on the other hand, the machine is not running, turn the hand wheel towards you so that the needle is in the highest position, when adjusting the stitch width knob.

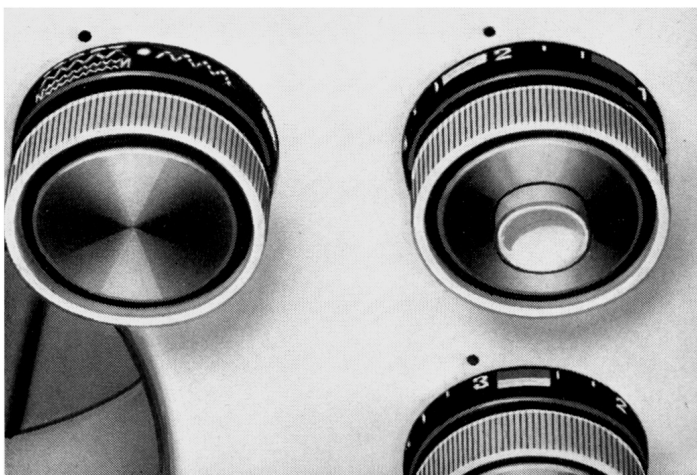
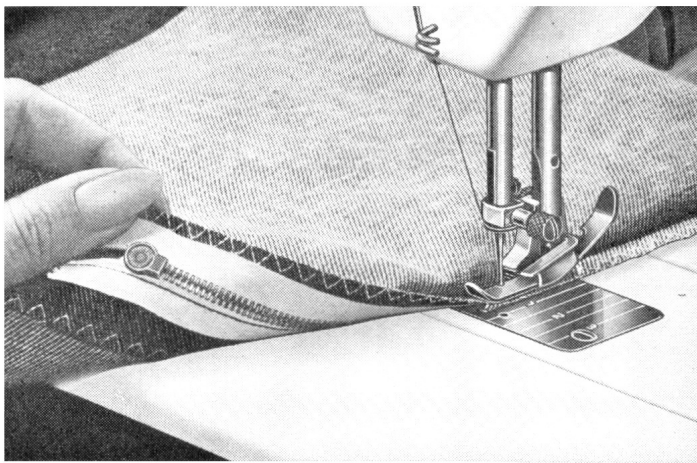
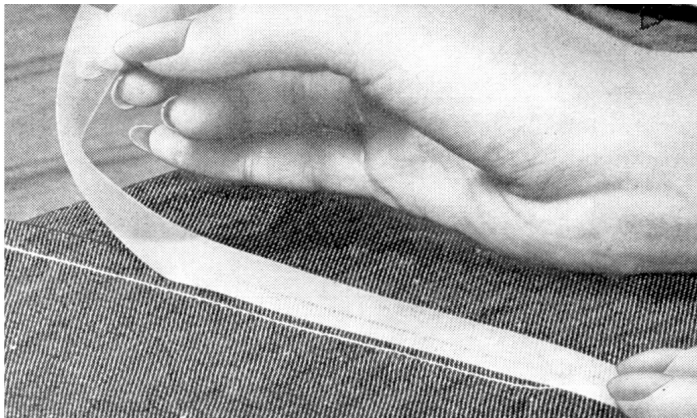

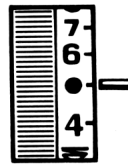
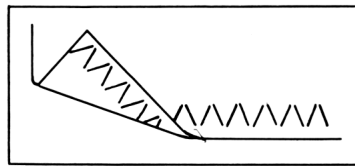
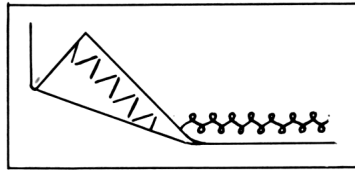
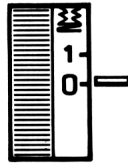
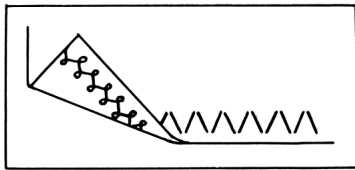

Thread tension

Before you begin to use the zigzag stitch, check that the thread tension is the same as when you did straight stitching. Use a scrap of material to see how the stitches look if you set them on the loosest, upper picture, respectively the hardest, middle picture, thread tension. The correct thread tension will look like that in the lower picture.

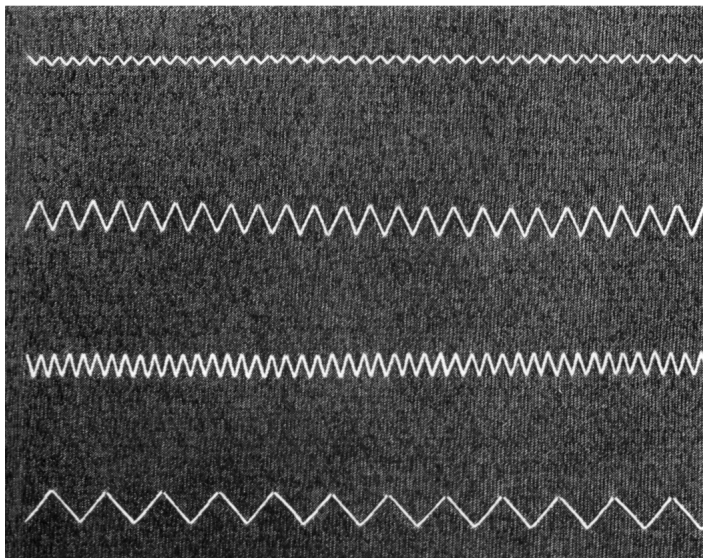

You can make any number of combinations of stitch width and stitch length. This is shown clearly in the illustration.

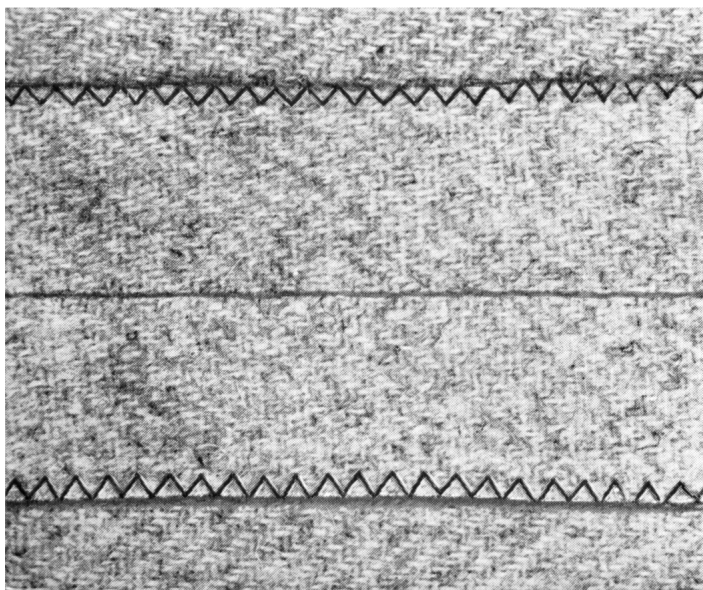

Overcasting

The adjustment must be adapted to the fabric you wish to sew. For example, for a medium-weight woolen material, 2 in length and 3 in width would be suitable. The result of this is shown in the picture. See that the needle catches the edge of the fabric. You can overcast each edge individually or, if the seam allowance is narrow, you can put the edges together and overcast them together. The edges should be trimmed before overcasting.

Three step zig-zag

You are now ready for the three-step zig-zag — the practical stitch for many different purposes and with which you can sew, for example, jersey, knitwear and towelling. Before adjusting, the needle must be set to the highest position by turning the hand wheel towards you. Then turn the stitch selector knob to the symbol for three-step zig-zag (▲▲▲), the stitch length knob to 1 and the stitch width knob to 4.

Overcasting in jersey should be done with three-step zig-zag because of the stretchable nature of the material. The straight stitching should also be replaced by an elastic stitch and in this case an elastic straight stitch is suitable (see page 25).

In terry cloth, seams should be overcast with three-step zig-zag. It is even better and stronger if you stitch the seams down onto the garment. Even though the stitching goes through on the right side of the fabric, it is hardly noticeable. Terry cloth can also be hemmed in the same way with three-step zig-zag. The illustration shows a seam sewed with straight stitching where the seam allowances have been stitched in the manner described. The arrow shows stitching sewn with thread the same colour as the fabric.

The edges of thin, easily frayed fabrics have a tendency to pucker when overcast with ordinary zig-zag. Three-step zig-zag is suitable for such fabrics.

Three-step zig-zag is also suitable for overcasting heavy fabrics. You should sew a double row of stitching in order to fasten the coarse threads in the weave.

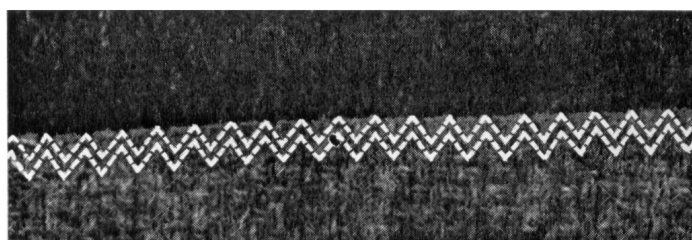
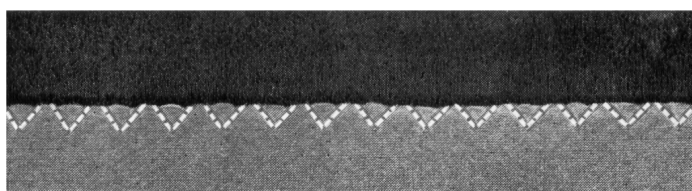
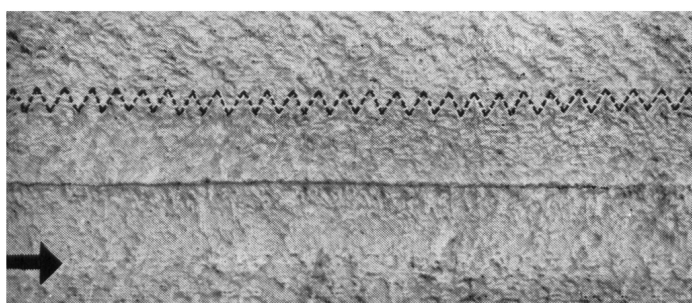
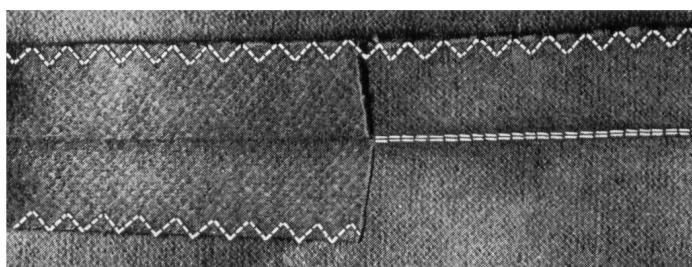
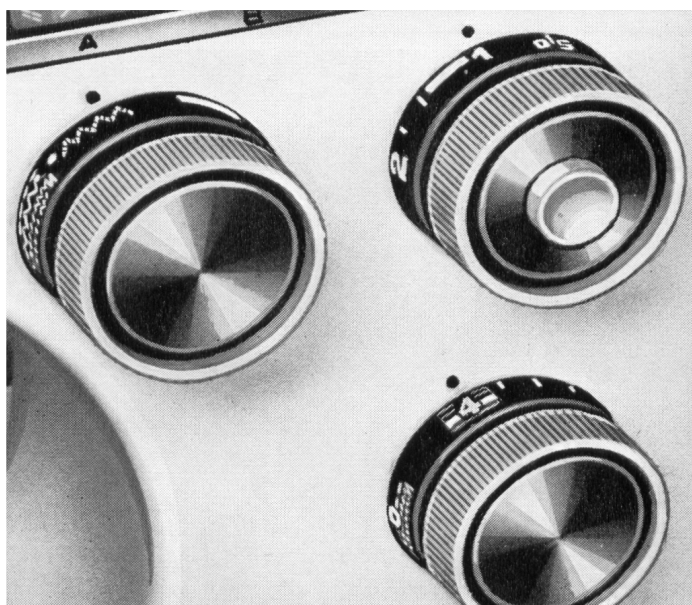
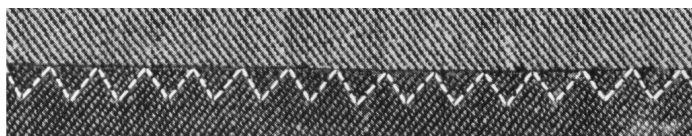

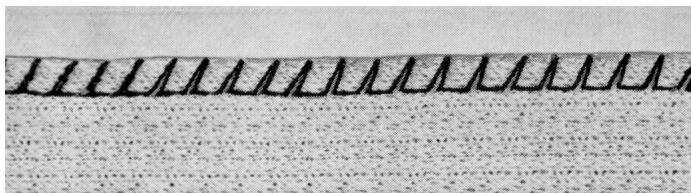

Overlock stitch

An overlock stitch is used for overcasting seams. It is elastic and binds the edge of the fabric well.

To obtain thin, flexible and elastic seams in knitwear, jersey and hand-knitted garments, use an overlock stitch to sew the parts of the garment together. This replaces both straight stitching and zig-zag overcasting.

Check that stitch former A is in position at the rear of the machine. If it is not, set the white dot on the stitch selector opposite the adjustment dot and insert seam former A in place of the one already in the machine. Make sure the seam former is correctly fitted by pressing it inwards. Then turn all three knobs to the blue symbol.

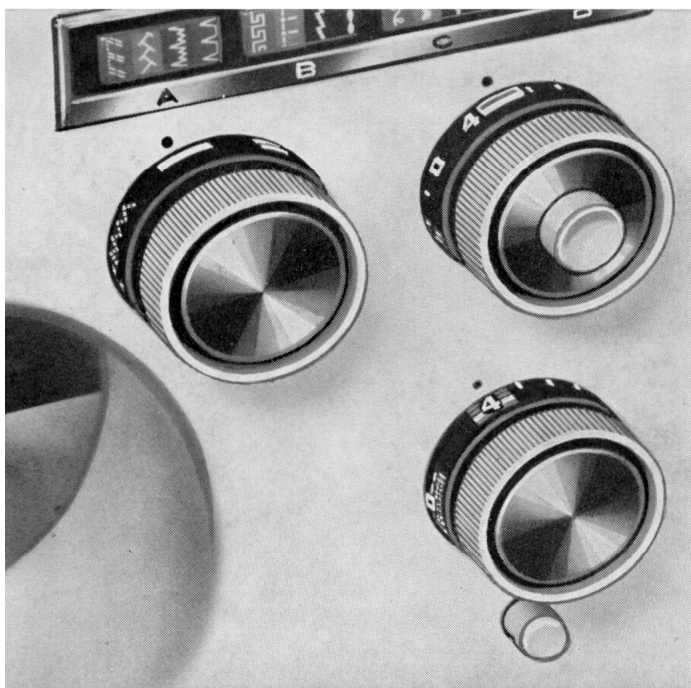

Blindstitching

Blindstitching is used for hemming skirts, for example, without the stitches showing on the right side. As you will see from the sketch, it consists of four straight stitches and one zig-zag stitch.

The symbol for blindstitching on the pattern scale is purple. Before adjusting, the needle must be set to the highest position by turning the hand wheel towards you. Then turn the stitch selector knob, the stitch length knob and the stitch width knob to purple symbol.

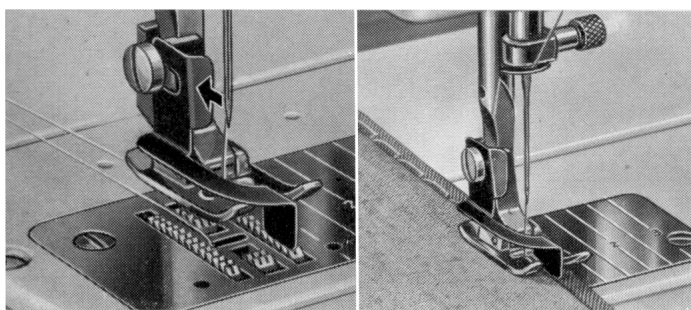

You will find the so-called hemming plate in the accessory box. Loosen the presser foot screw a little and slide in the hemming plate as shown in the picture. Tighten the presser foot screw and make sure that the hemming plate sits squarely down on the presser foot. The plate serves as an edging guide.

Fold the fabric as shown in the sketch and then set all the knobs to the purple symbols. This adjustment is an average setting, which means that you can either increase or decrease the stitch length to vary the distance between the catches.

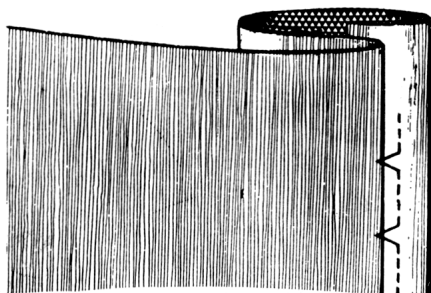

Before beginning to sew, engage the reduction gear. Make quite sure that the folded edge follows the blindstitching plate.

Stitch width may also be varied. On the upper fig. can be seen how the stitches fail to reach the edge of the fabric. You will then either have to increase the stitch width or else make sure that the edge of the fabric exactly follows the blindstitching plate.

On the middle fig. the stitch width has been increased too much, leading to excessive "bite".

On the lower fig. is shown, how a correctly sewn blindstitched hem should look. The seam catches only one thread of the folded edge. By using thread the same colour as the fabric the result will be virtually "invisible".

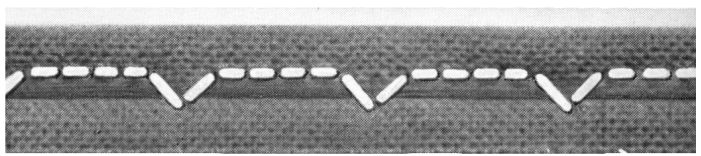
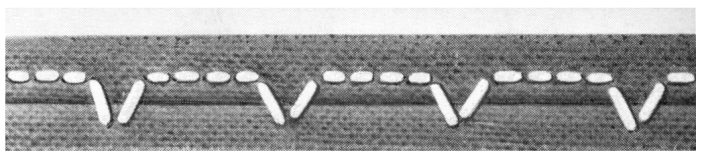
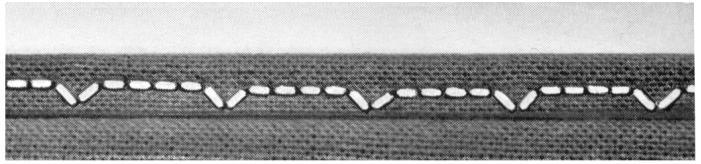

Elastic blindstitch

Instead of the four straight stitches, the elastic blindstitch has small zig-zag stitches between the larger zig-zag stitches. This stitch is used for hemming elastic fabrics, particularly those that stretch sideways a lot. The elastic blindstitch is coloured orange on the pattern scale under A. Check that seam former A is in the machine and turn all knobs to orange symbols. Fabric folding and fine adjustment of the stitches are carried out in exactly the same manner as for blindstitching.

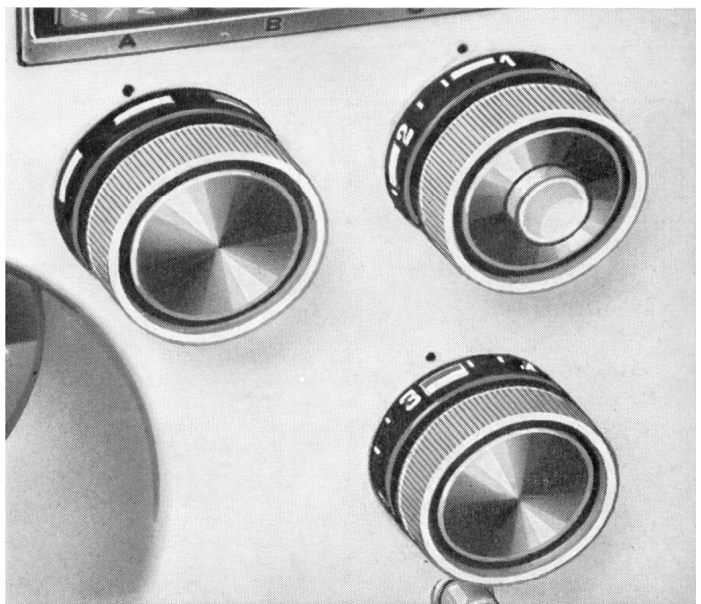

Elastic straight stitch

As the name implies, the elastic straight stitch is a triple-lock stitch combining stretchability and strength. It is particularly useful for crotch sewing and for sleeve insertion, as well as for sewing in jersey and other stretch materials.

When you sew on the bias of an ordinary material the seam should be elastic, e. g. on a kimono-sleeve.

The elastic straight stitch can be used for decorative purposes, too.

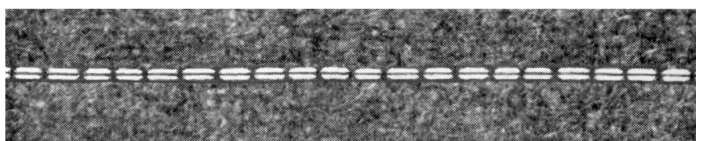
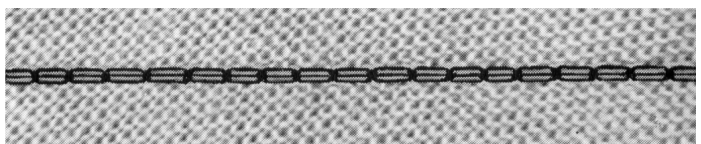
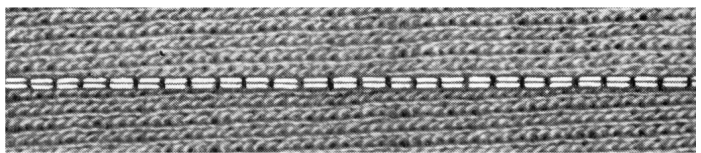
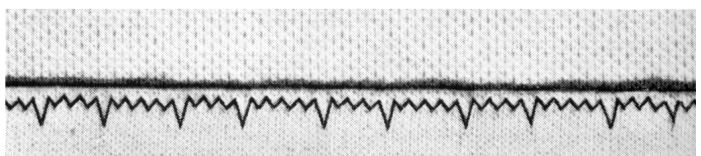

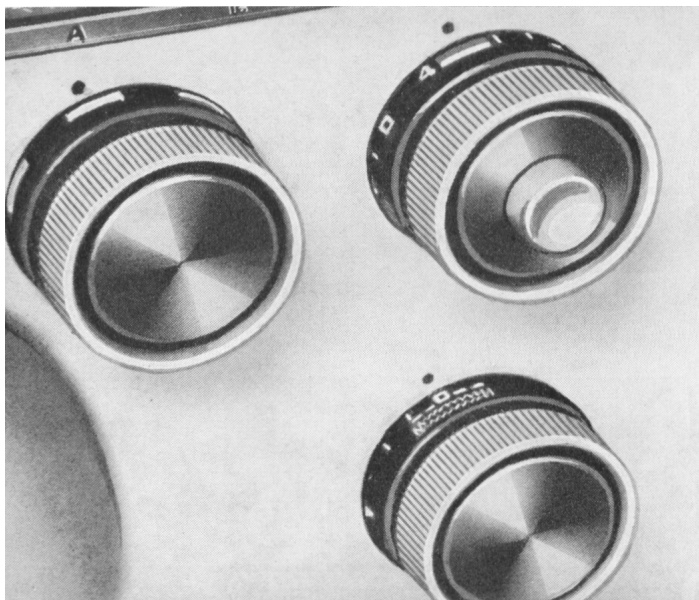

Elastic straight stitch

(continued)

Insert seam former A in the machine. Set the stitch selector and the stitch length knob at the yellow symbol and the stitch width knob at 0. Test sew on a scrap piece of material and check the regularity and appearance of the stitches. Equalize the length of the forward and reverse stitches by means of the stitch length knob.

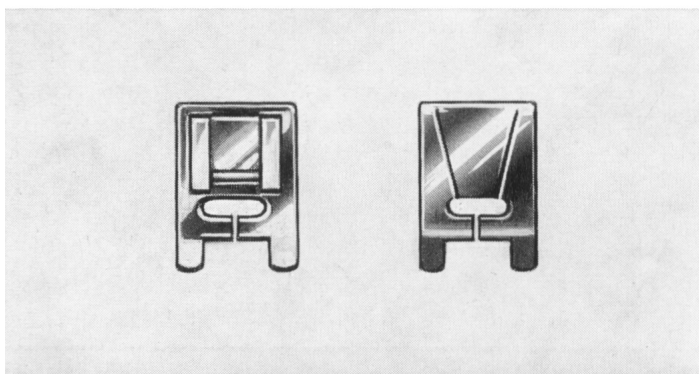
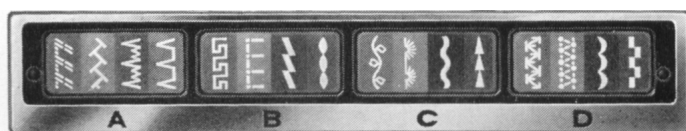

Pattern stitching

Before you begin to sew patterns, you should change the presser foot. You will find the pattern presser foot (41 11 395) in the accessory box.

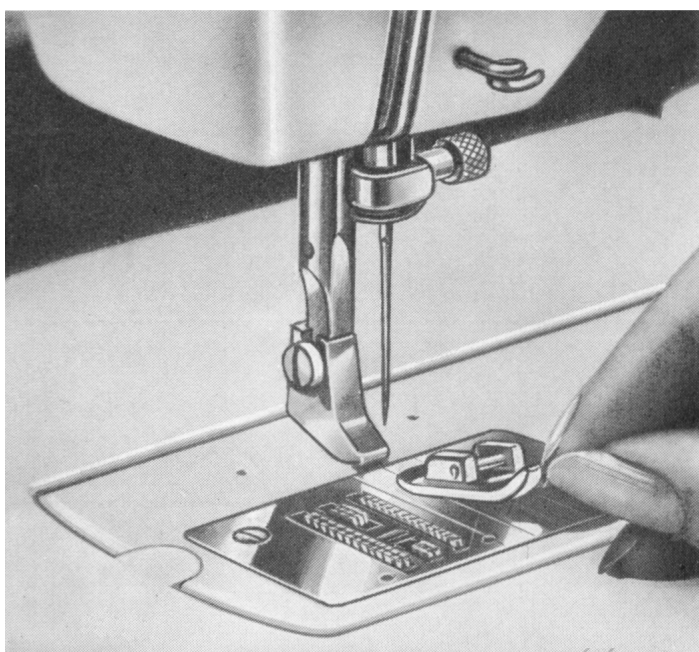

Remove the presser foot which is on the presser bar and exchange it for the pattern presser foot. When it is in position, select the stitch you wish to sew.

Then check that the correct seam former is inserted. If not, set the white dot on stitch selector knob opposite the adjustment dot, take out the seam former at the back of the machine and replace it with the seam former you wish to use.

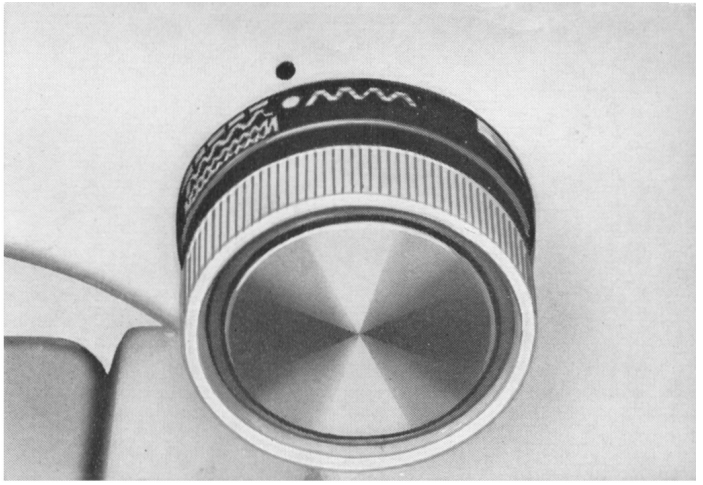

After having placed the seam former in position, turn it until you can feel that it is engaged.

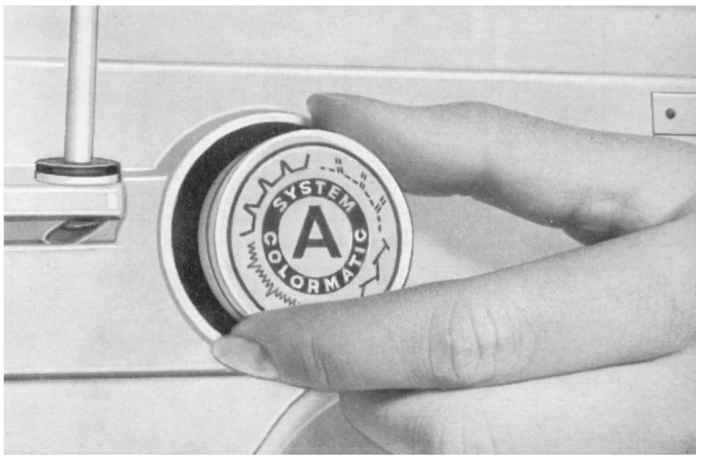

You should now set the stitch selector knob, the stitch width and stitch length knobs for pattern stitching. Before doing this, check that the needle is in the highest position. Then set all the knobs onto the colour of the stitch you wish to sew. On the stitch width knob the yellow, green, red and blue adjustments are all at the same position. Remember to start a little way in from the edge of the fabric. Loosen upper thread tension slightly for red and green patterns, setting the thread tension knob to the buttonhole symbol.

Carry out fine adjustment of the yellow and blue patterns by means of the stitch length knob until the pattern is neat and even.

Use embroidery thread, about which you can read under "Do you have the right thread?" on page 12.

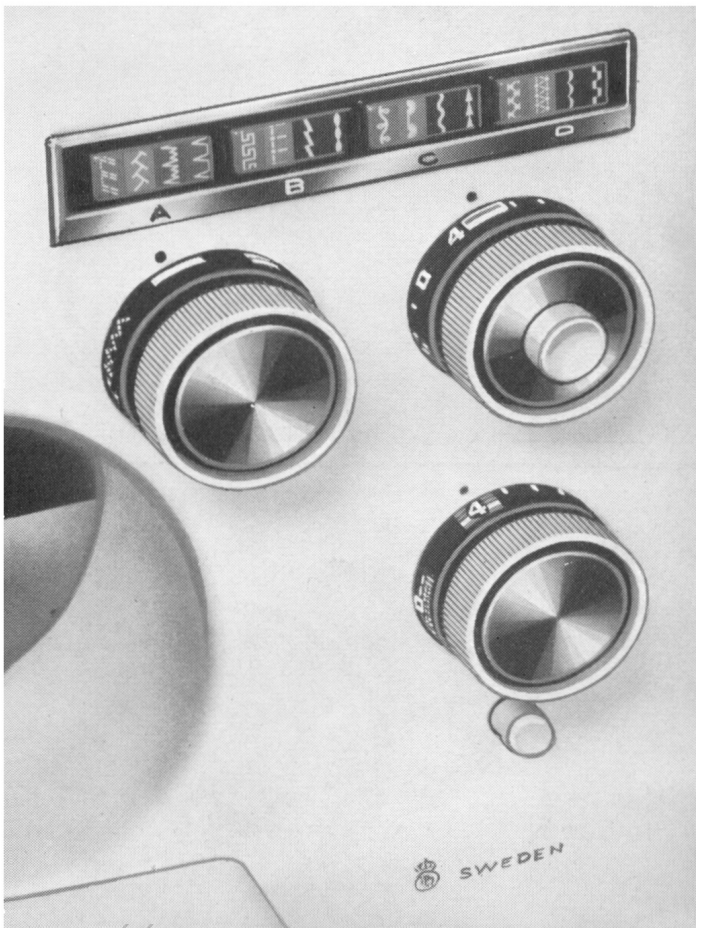

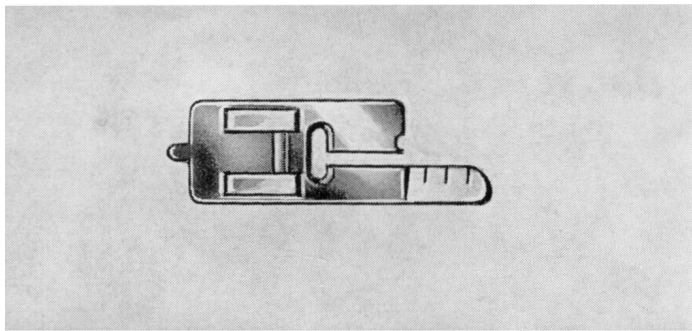

Buttonholes

In order to sew buttonholes, change over to the buttonhole foot (41 11 650). You will find this in the accessory box and it is attached in the same way as the ordinary presser foot. The buttonhole foot is graduated so that you can make all the buttonholes exactly the same length.

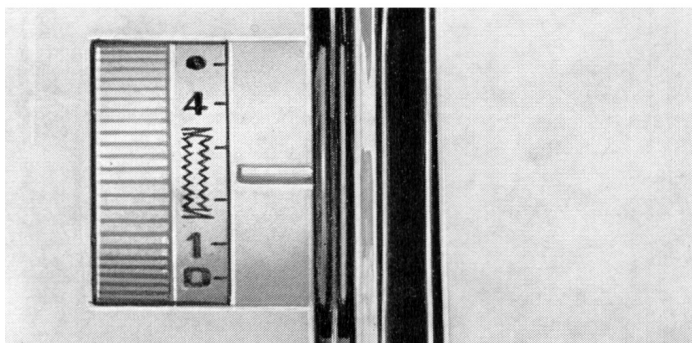

Loosen the thread tension by turning the thread tension knob to the buttonhole symbol.

Perhaps it should be pointed out, that the buttonhole will look better and more even if you use a fine thread. For further details, see under "Do you have the right thread"?

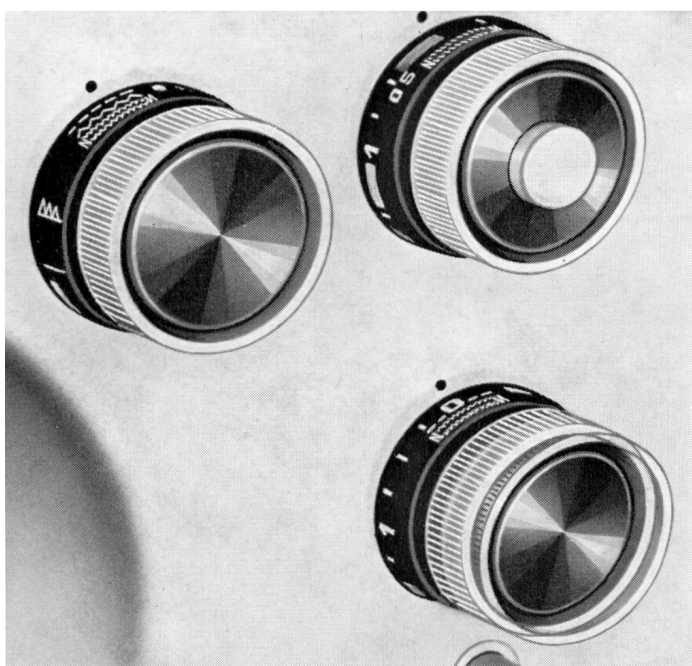

Now to the actual setting. Begin as usual by making sure that the needle is in the highest position. Set the stitch selector knob to the buttonhole symbol (). After this, set the stitch length knob to the buttonhole symbol. Then set the stitch width knob to 0 and pull it out towards you.

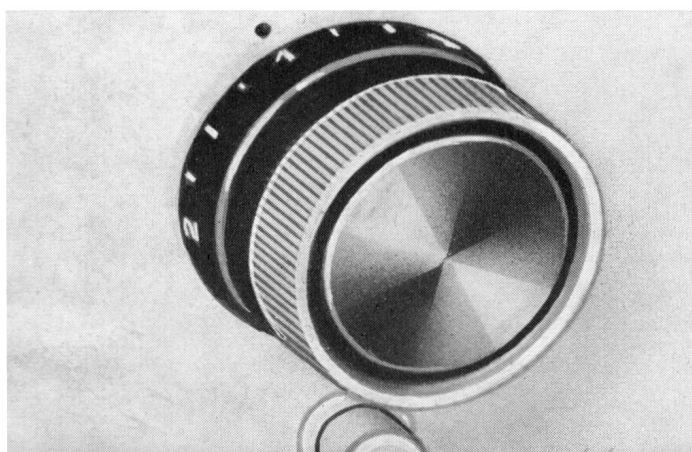

After having set the stitch width knob to 0 and pulled it out, turn it to the right to 1. Put the fabric under the presser foot and place the marking, remembering that the machine begins to sew in reverse. The buttonhole-sewing is shown step by step on the next page.

Mark out the buttonholes by making an imprint threadwise with the blunt edge of the buttonhole knife. If the fabric is washable you can mark it with a pencil. Use thread marks on delicate fabrics.

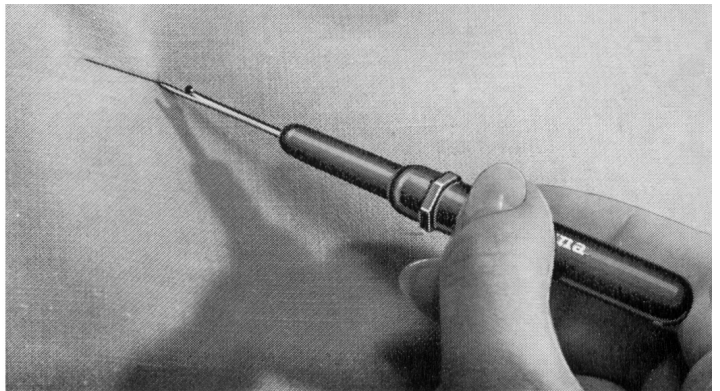

Start sewing with the stitch width knob at 1. Note that the machine sews the first column in reverse. If the stitches are not sufficiently close, reduce the stitch length slightly. When you have sewn this column to the right length, stop the machine with the needle raised and turn the knob to 2.

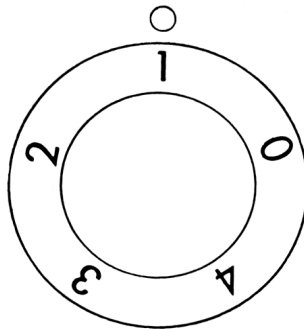

The next step is to form the first closing bar. Press down the foot control to sew 3—4 stitches while holding back the fabric. Then stop the machine with the needle raised and turn the knob to 3.

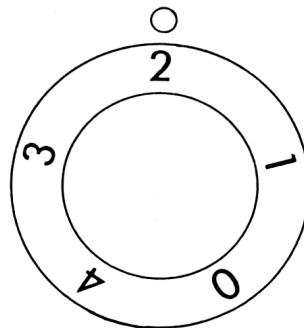

Now sew the other column the same distance as the first one. Stop the machine with the needle raised and turn the knob to 4.

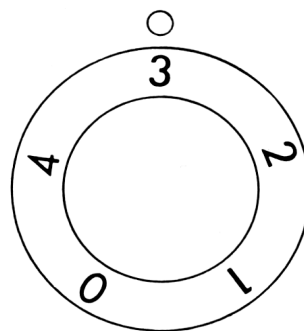

In position 4 the machine makes the final closing bar. Make 3—4 stitches while holding back the fabric, stopping the machine with the needle raised. Then turn the knob to 0 and lock the threads with a few stitches while holding back the fabric. *If you wish to make more buttonholes, just re-set the knob to 1 and follow the same procedure. When finished, press in the knob at 0, after which it will again function as the ordinary stitch width knob.*

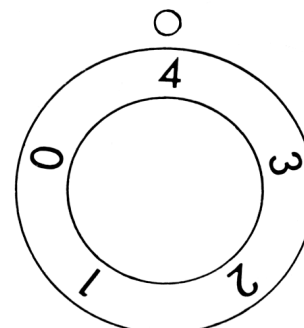

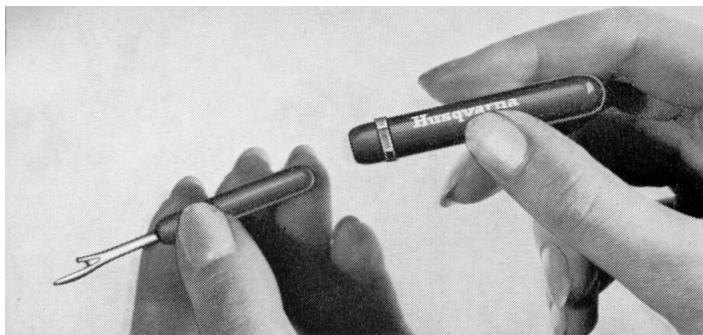

Buttonholes

(continued)

The buttonhole knife, which you will find in the accessory box, is equipped with a sheath which, when taken off, can be pushed onto the back of the knife and thus provides a good handle.

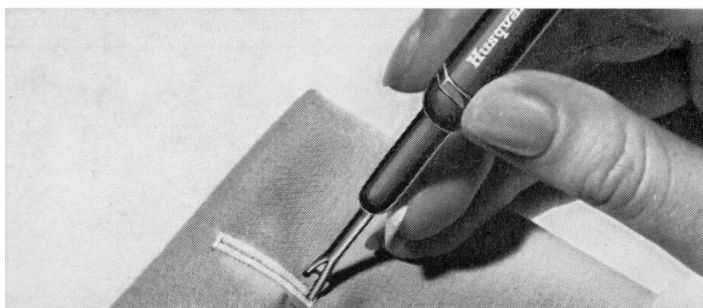

When you have finished sewing all of the buttonholes, it is time to cut them. Do this by piercing the fabric at right angles until the curved edge reaches down to the button hole.



Then incline the knife towards you and move it carefully forwards so as not to cut through the seam threads. The small red bead serves as a guide. Stop cutting when it reaches the closing bar.

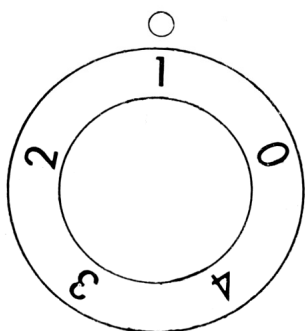

Reinforced buttonholes

Garments subject to heavy wear or buttons subject to special strain may sometimes require even stronger buttonholes and this is how you make them:

Pull out the knob on 0, turn it to 1 and sew the first column in exactly the same way as for an ordinary buttonhole but with slightly longer stitches.

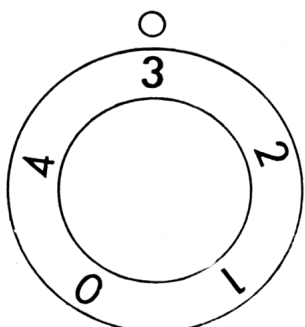

When the column is sufficiently long, stop the machine with the needle raised and turn the knob to 3. Sew the second column without making any closing bar.

When the second column is the same length as the first, stop sewing with the needle raised from the fabric. Then continue by turning to 1 again and sewing the first column once more. If you should have difficulty with the feed, increase the stitch length slightly.

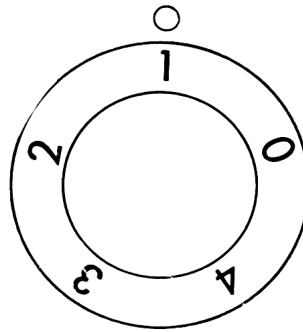

When this is finished, set the knob to 2 and make 3—4 closing stitches while holding back the fabric. Make sure that the needle is raised when making the next setting.

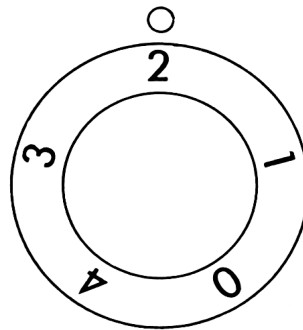

Now turn the knob to 3 and sew the second column once more.

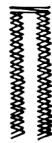
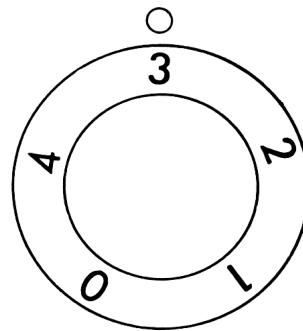

Finish off the buttonhole by turning the knob to 4 and sewing 3—4 closing stitches while holding back the fabric. Then turn the knob to 0 and lock the threads by sewing a few stitches while holding back the fabric.

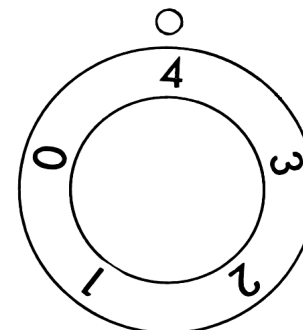

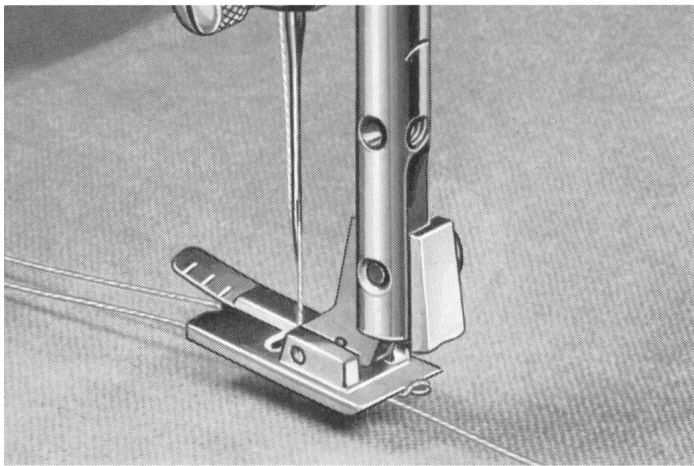

Corded buttonholes

Take some heavy thread, such as buttonhole twist or extra strong thread. Attach the thread loop as shown in the picture around the "heel" of the buttonhole foot, stretch the thread and lower the presser foot. The buttonhole is sewn as usual. Allow the gimp to follow around without pulling it.

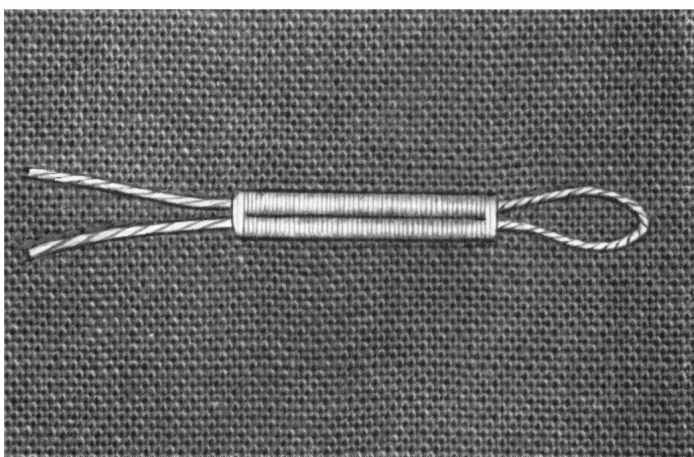

When this is ready, pull the ends of the gimp thread so that the loop forms a reinforcement at one end of the buttonhole. Cut off the thread at the other end or, even better, thread the ends through to the reverse side and tie them.

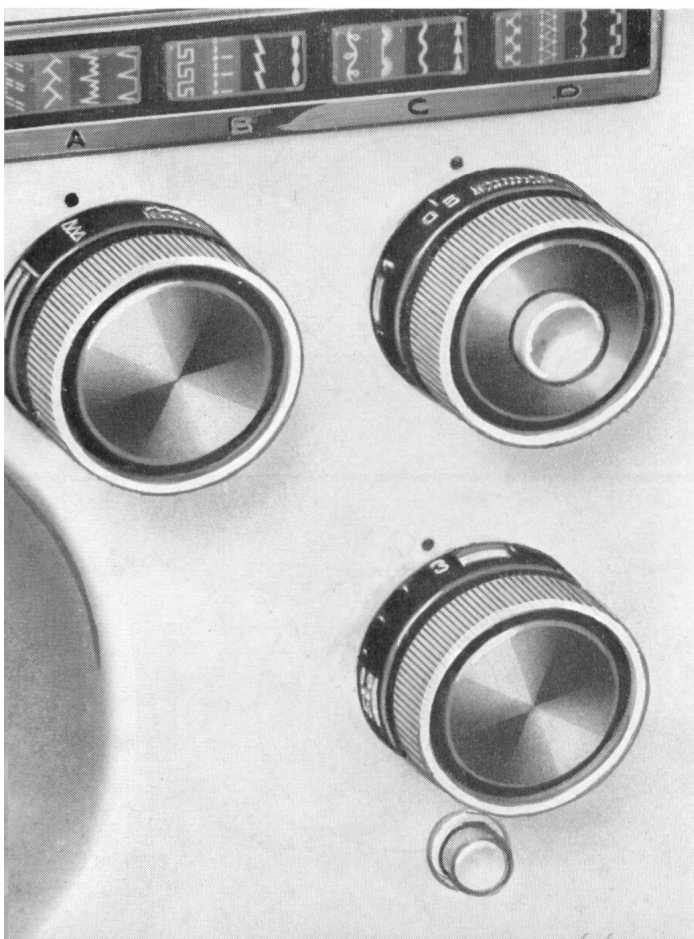

Sewing on buttons

For sewing on buttons, set the stitch selector knob to the symbol () at the left-hand starting position. You can disregard the stitch length since the feed mechanism must be disengaged. We will return to this shortly. Adjust the stitch width to suit the hole in the button concerned. Most machine-made buttons, however, have a standard of spacing $1/8''$ — $5/32''$ (3—4 mm.) between the holes regardless of the size of the button.

Remove the presser foot and lower the feed dog by pressing the drop feed push-button inwards/downwards so that the button is held in this position. When the button has been sewn on and you wish to return to ordinary sewing, press the feed dog lowering button inwards/upwards so that it releases from its previous position.

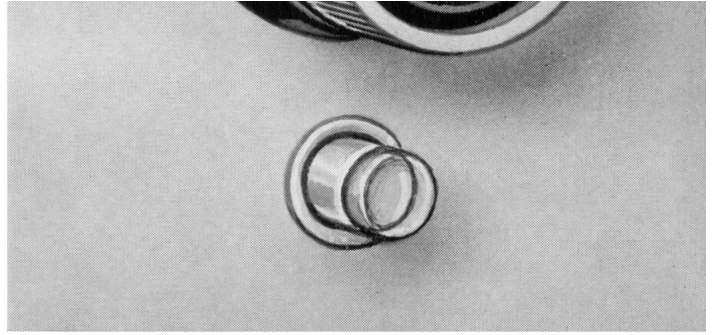

Place the button and lower the presser bar. Set the stitch width knob to a suitable setting — about 3 — turn the hand-wheel towards you and test carefully that the needle goes through the centre of first one hole and then the other. Depress the foot control without disturbing the position of the button. Hold both thread ends behind the bracket and sew 5—6 stitches. Then move to the other holes and repeat the process. Set the stitch width knob to 0 and lock the thread.

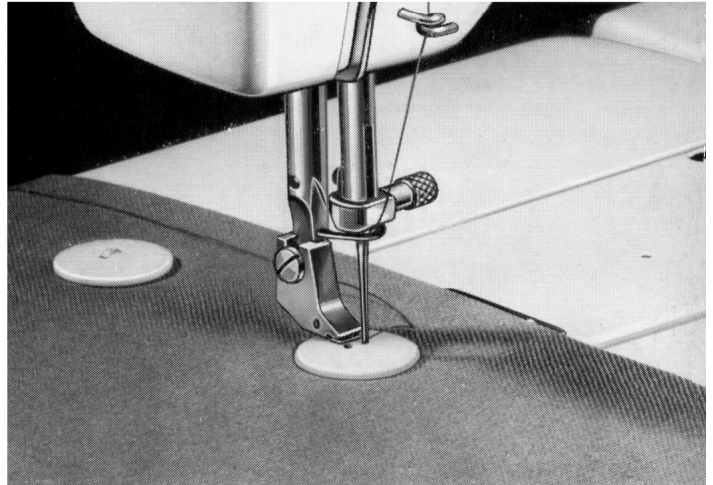

Button reed

When sewing buttons on garments, a "stem" is often desired so that the button stands slightly proud of the fabric. You can use the button reed for this. Use the thin end when sewing buttons on thin fabrics, the thick end for heavier fabrics.

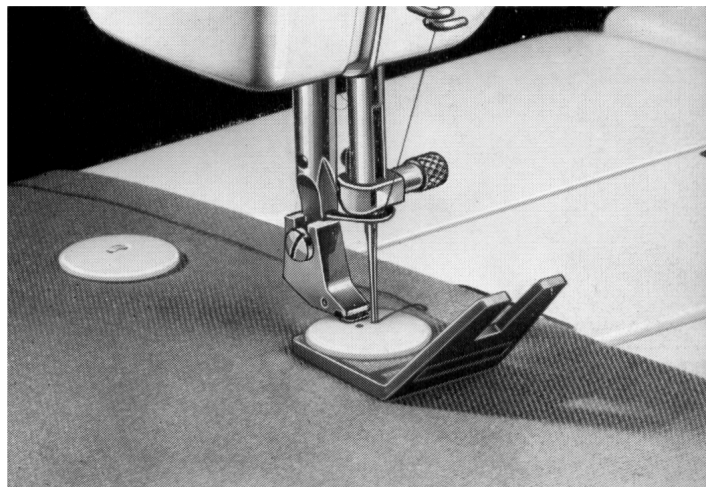

Mark the place where the button is to be sewn on and place the garment under the bracket. Insert the button reed as shown in the illustration, with the marking in the centre of the opening. Place the button on top and lower the presser bar. Sew the button on in the ordinary manner and remove the button reed. Pull down the threads between the fabric and the button, wind the threads a few times round the stem and secure them.

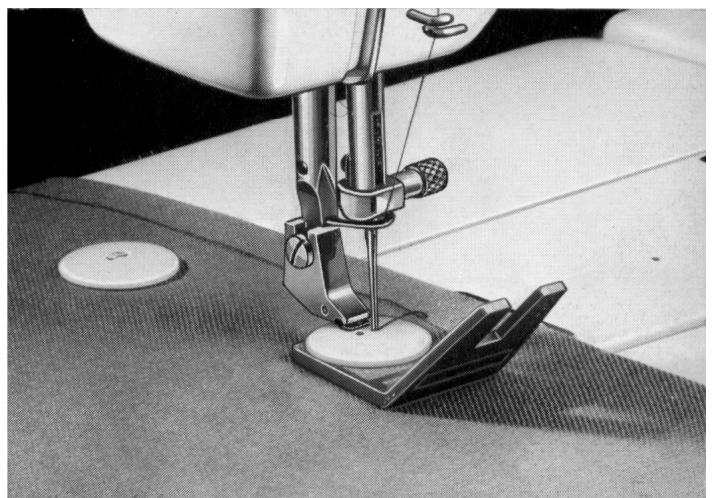

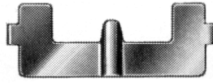
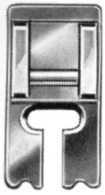

Raised seams

Exchange the ordinary needle for a twin needle and be sure to see that it is pressed up high into the needle clamp. Change to presser foot 41 11 389 and fit the raised seam attachment with its straight edge toward you. If you wish to use a gimp cord, lay this under the raised seam attachment when you put it on. Place a spool of thread on each of the spool pins and thread on both sides of the middle tension disc. Continue threading in the same way as for a single thread but with one thread through each hole in the thread take-up lever. And finally, one thread in each of the needles.

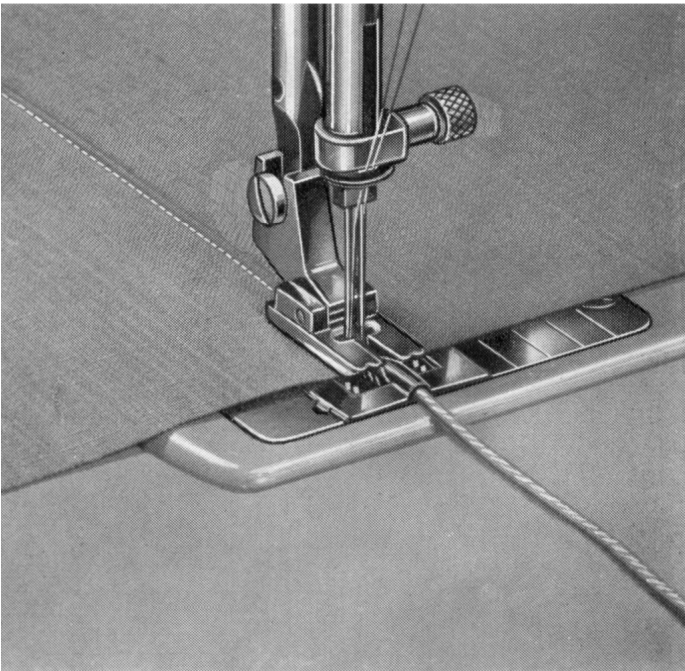

In order to prevent the threads from becoming entangled, it is advisable to thread one at a time. Adjust the machine for straight stitching. The height of the raised seam is adjusted by means of the thread tension — the harder the thread tension the higher the seam will be. If you are using a gimp cord, first pull it out well behind the presser foot and then it will only be necessary to see that it runs freely while you are sewing.

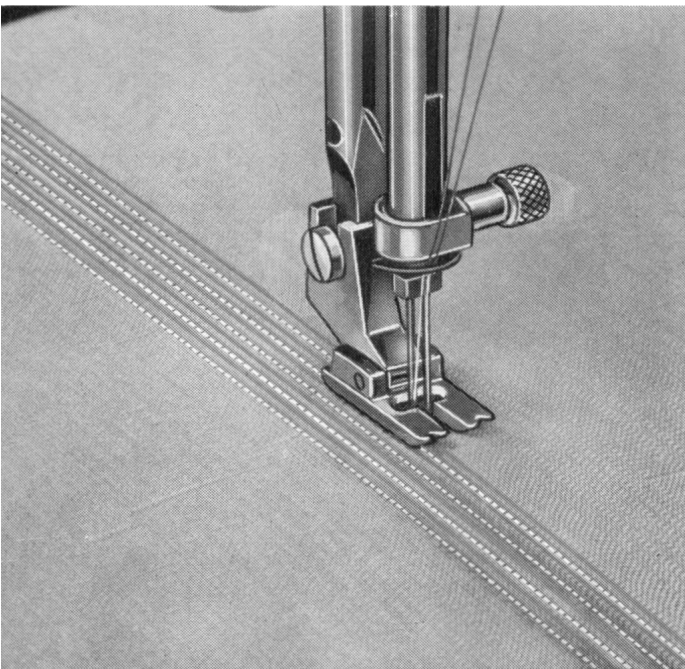

Parallel raised seams

If you wish to sew several parallel seams, you can use the grooves on the bottom of the presser foot as edge guides. Place the previously sewn seam to the left or to the right of the one you are about to sew and let the presser foot guide the work.

Hemmers

The hemmers are used when you want to sew long hems in fabrics which are not excessively thick. Hemmer 41 11 385 gives a hem about $\frac{3}{16}$ " (5 mm.) wide.

The edge which is to be hemmed must be trimmed and straight. You should fold the edge over twice — first $\frac{5}{32}$ " (4 mm) and then $\frac{3}{16}$ " (5 mm.). You only need to fold it in this way in the beginning of the hem, the hemmer itself will take care of the rest of the work.

Insert the folded edge of the fabric into the hemmer so that it comes properly in under the presser foot. Lower the presser foot. Sew a stitch where the hem starts. Hold the ends of the thread firmly in your right hand and lift the hemmer somewhat in order to get the edge of the fabric into the scroll.

Hold the fabric as shown in the picture and let the machine feed it without pulling or holding the fabric back. If the edge of the material tends to slide out of the hemmer, guide it somewhat to the right. If too much material enters the hemmer, draw the fabric somewhat to the left.

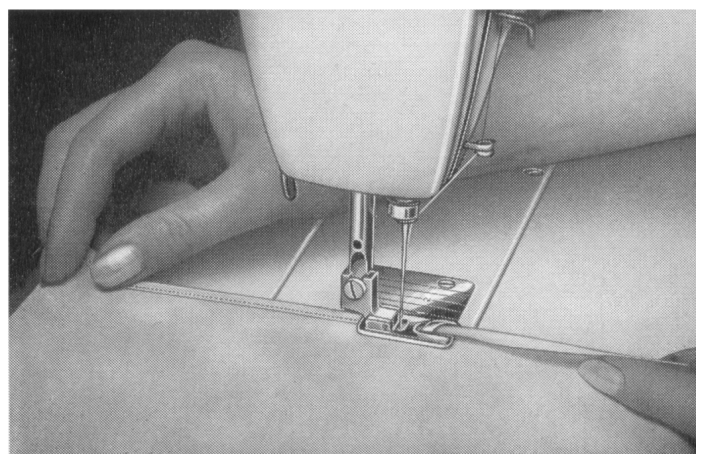
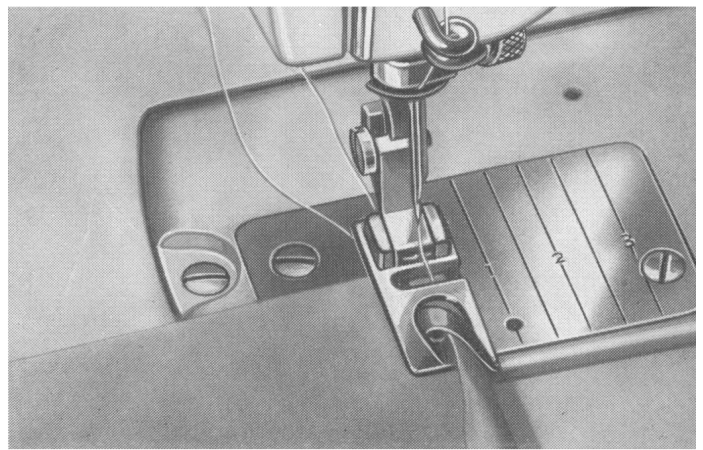
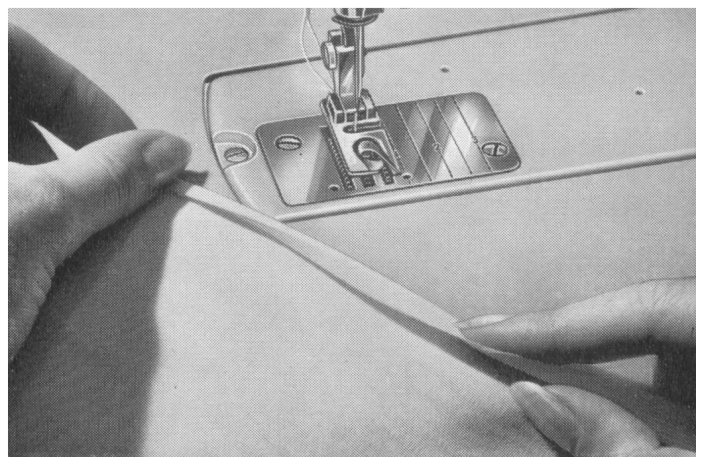
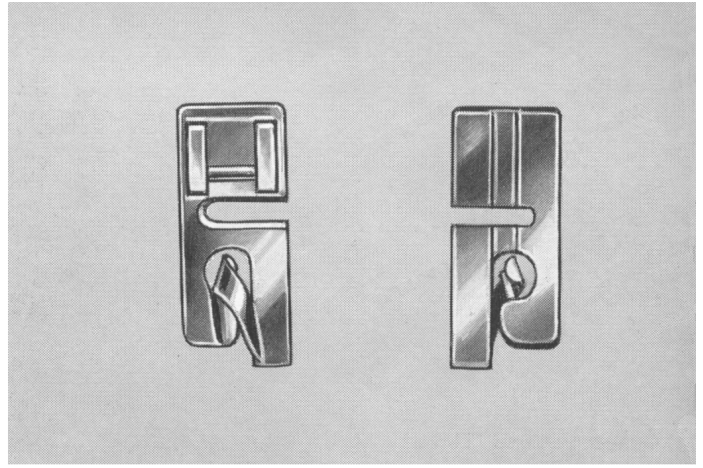

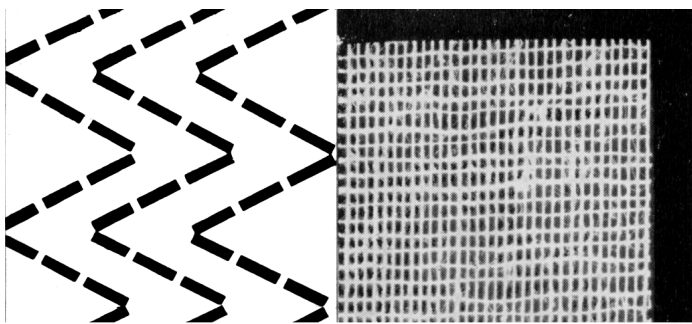

Quick mend

is a Husqvarna method which helps you to do darn and mend neatly. The basic stitch is the three-step zig-zag. You also need a piece of tarlatan (stiffened gauze). The stiffness in the tarlatan disappears in the next laundry and the mending "melts" into the surrounding fabric.

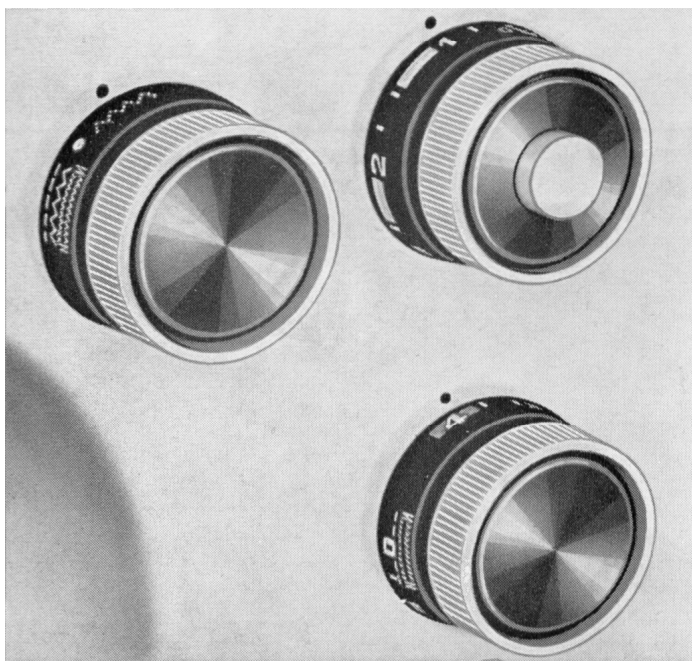

The picture shows how the various stitches are woven into each other. This is done by allowing the stitch to run back and forth while the work is moved slightly sideways. You therefore sew back and forth across the fabric without turning it — sewing is done with the help of the reverse feed button.

Set the stitch selector on the symbol for three-step zig-zag (Z). Then it is time to set the stitch length knob on 0.5—1, depending on the type of fabric to be mended. Thin fabrics require a shorter stitch length than thick ones. Finally, the stitch width knob should be set on 4. With regard to the thread, see the chapter "Do you have the right thread?"

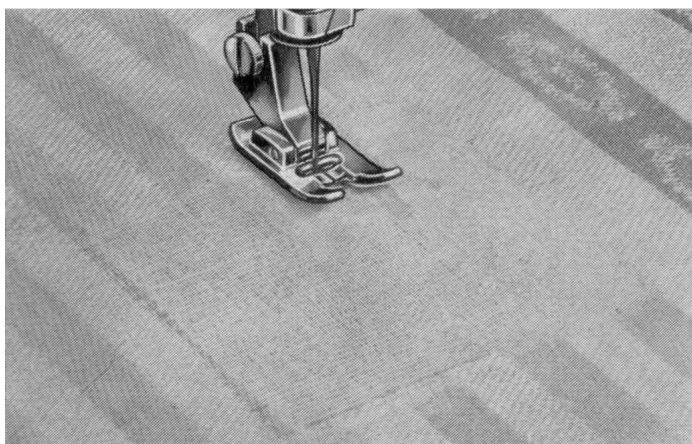

Threadbare patches

Cut out a piece of tarlatan large enough to cover the worn place. Lay it on the fabric and sew on the right side with "Quick-Mend". For short seams it is not necessary to turn the work around since you can sew back and forth with the reverse feed button. The more threadbare the patch, the shorter the stitch.

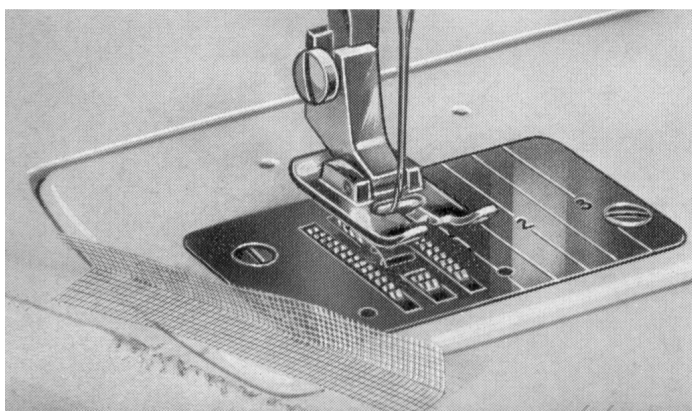

Worn edges

It is not uncommon that the selvages of serviettes, tablecloths and towels are worn in the laundry. Fold a strip of tarlatan around the edge and sew over the whole piece with Quick-Mend. If a piece of the fabric is missing, this must be replaced with patching material or a double fold of tarlatan before you sew across with the Quick-Mend. The stitch length should be about 0,75—1.

Small burns in cloths

That people are careless and burn holes in a cloth is unfortunately a common occurrence. Cut away the burned part, place a double bit of tarlatan over the hole and stitch closely all over on the right side with the "Quick-Mend". The tarlatan helps to hold the fabric in place and prevents it from puckering at the stitches. A small darn like this one is practically invisible after laundering. Stitch length 0.5.

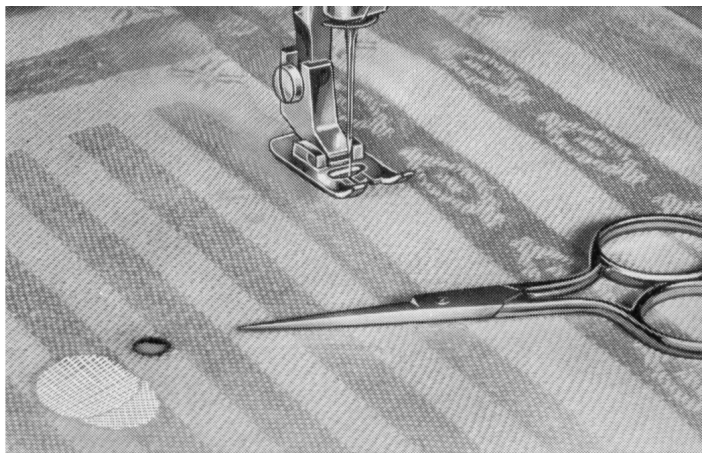

Larger holes

If the hole is larger than a fingernail, it must be filled in with some patching material — or if none is available — a double layer of tarlatan — before it is stitched over with the Quick-Mend. Cut out a piece of patching material which is larger than the hole. Stitch this onto a piece of tarlatan which has been cut about 3/16" (5 mm.) larger all around than the patching material. Trim the edges of the hole, place the patching material underneath and stitch it down all around.

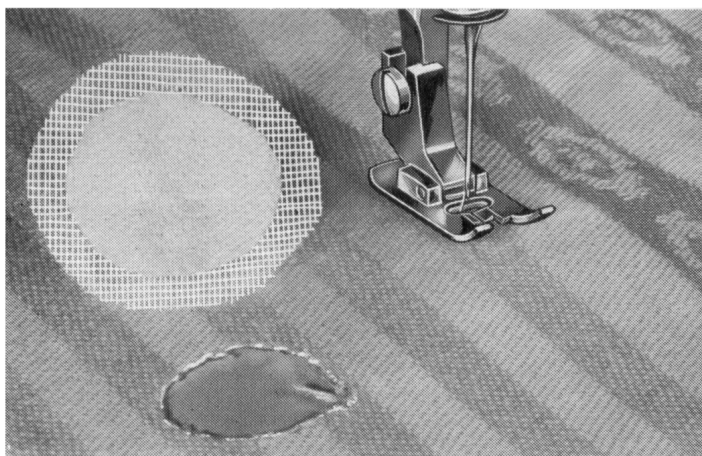

Sew on the right side with small stitches using "Quick-Mend". Be careful to see that the mend covers the tarlatan which is on the reverse side of the fabric. Stitch length 0.75—1.



Torn corners

Not even such a boring job is difficult with the Quick-Mend. Cut out a new corner of the patching material similar to that which has been torn off. Stitch the new corner onto a piece of tarlatan.

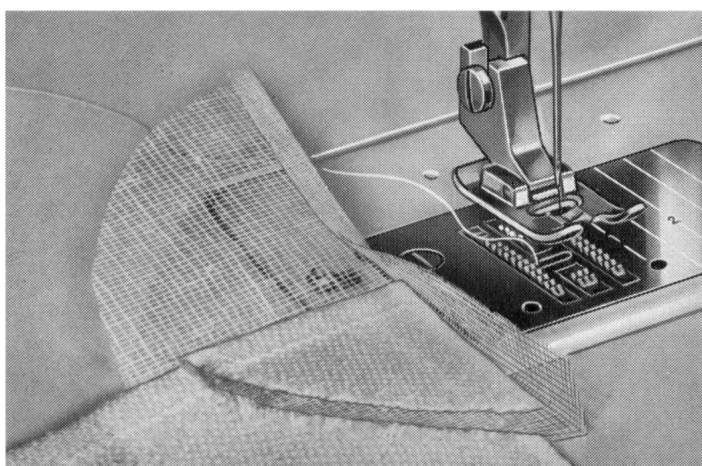



Torn corners

(continued)

Fit in the new corner which is sewed onto the piece of tarlatan so that it is edge to edge with the towel.

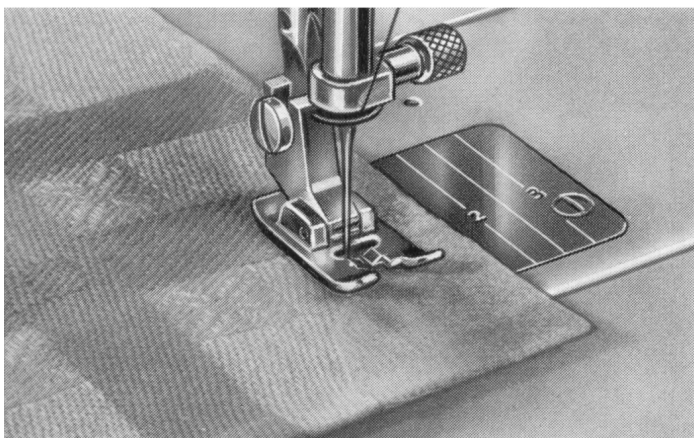

Fold the piece of tarlatan over the corner. Fold in the edges neatly and sew over with the "Quick-Mend". You will be surprised how little the mend shows after the material has been washed.

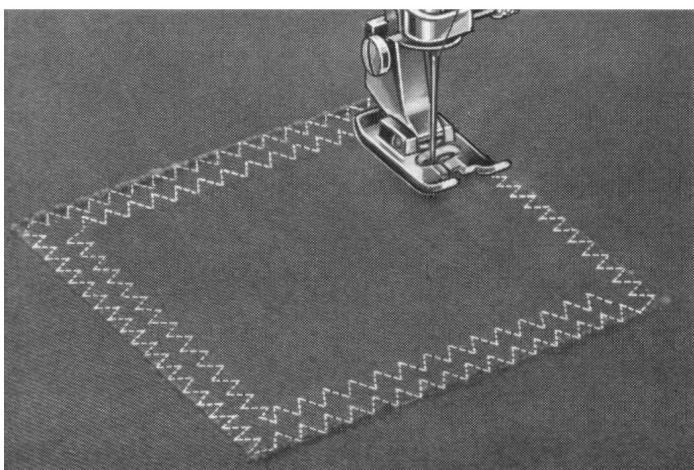

Patching

Large holes in towels, sheets, etc. are most easily mended by means of a patch sewed on with "Quick-Mend". Cut out a patch of the patching material large enough to cover the worn part completely. Sew the patch on the right side with Quick-Mend and cut away the worn material on the reverse side about $\frac{3}{16}$ — $\frac{3}{8}$ " (0.5—1 cm.) from the stitching, and sew the edges of the patch down with Quick-Mend. After this you can sew one or more Quick-Mend seams all around in order to strengthen the mend still further. Stitch length 1.

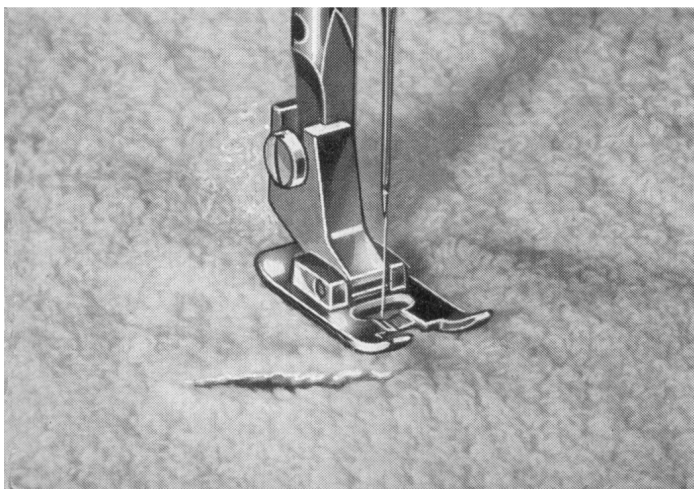

Patching terry cloth

Cut out a piece of terry cloth and sew it on with three-step zig-zag over the worn spot which has first been trimmed. Sew back and forth over the whole patch with the Quick-Mend using long stitches. Stitch length 0.75—1.

Tears in garments

Clothes can easily be torn by being caught up in something. To repair such a tear, place a piece of lining fabric under the tear, arrange the torn threads and, if necessary, fill in with a small piece of the same fabric. Then stitch over the tear with Quick-Mend. Trim the lining fabric on the inside. Stitch length 0.75—1.

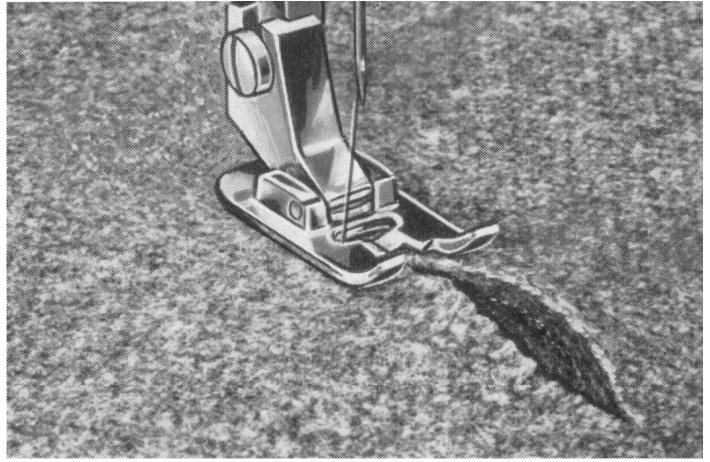

Let-in patch

Trim the hole and then cut out a patch of the fabric large enough to completely fill the hole. Attach the patch to a larger piece of lining fabric — preferably taffeta — with a couple of pins and place it under the hole. Make sure that the edges fit together well and stitch directly across the join with Quick-Mend. Sew a couple of extra rows of stitching if the patched place will be subjected to wear. Stitch length 0.75—1.

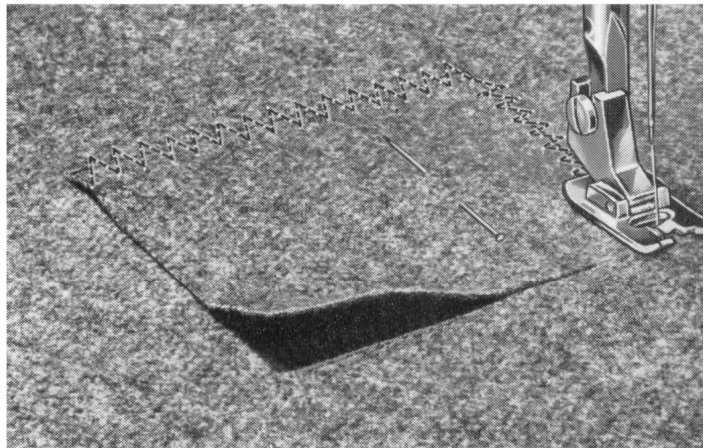

Patching knitwear

Trim the hole and cut out a piece of knitwear to cover the hole. Sew on with three-step zig-zag and reinforce by sewing once or several times around the hole. Tears in knitwear are mended by placing the edges together and sewing across the joint with three-step zigzag. Then reinforce them by sewing across the tear a couple of extra times. This is most suitably done by turning the fabric each time. Stitch length 0.75—1. Slacken the thread tension slightly and the stitches will be more elastic.

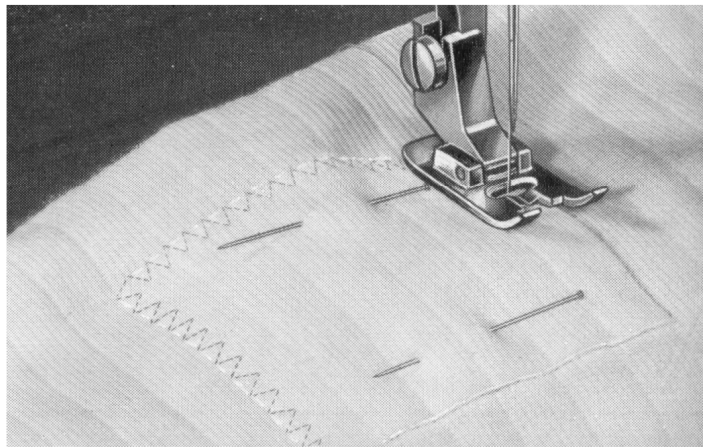

Broken seams

Broken seams in underwear are mended by sewing them together with three-step zigzag. Torn lace can also be mended with Quick-Mend using the thinnest possible mending cotton. You can use a piece of tulle as the mending material. Stitch length 0.75—1.

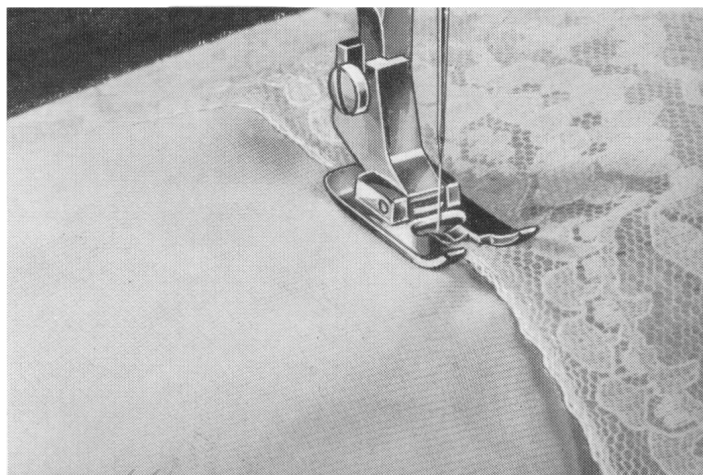

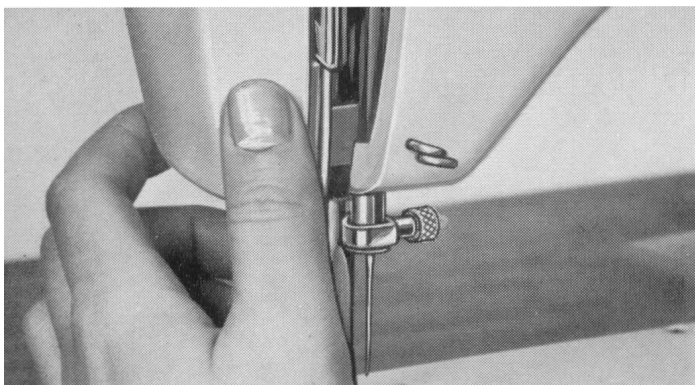

Presser foot pressure

Presser foot pressure can be adjusted with the aid of a graduated knob located behind the cover on the left-hand side of the machine. Open the cover as shown in the illustration and turn outwards. When the cover is closed again, see that the thread is not jammed.

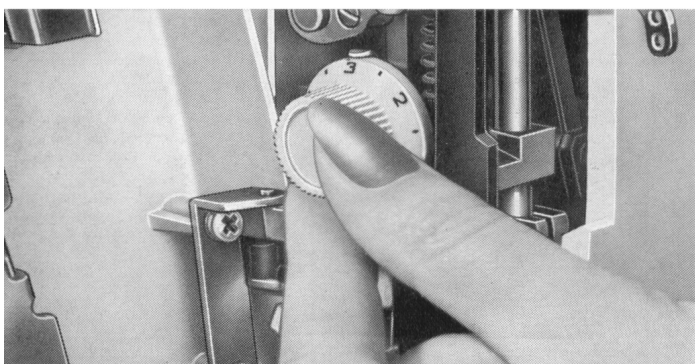

Set the knob in position 3 for normal pressure but for very thin fabrics it may be better to reduce the pressure somewhat, i.e. to set the knob at a lower figure.

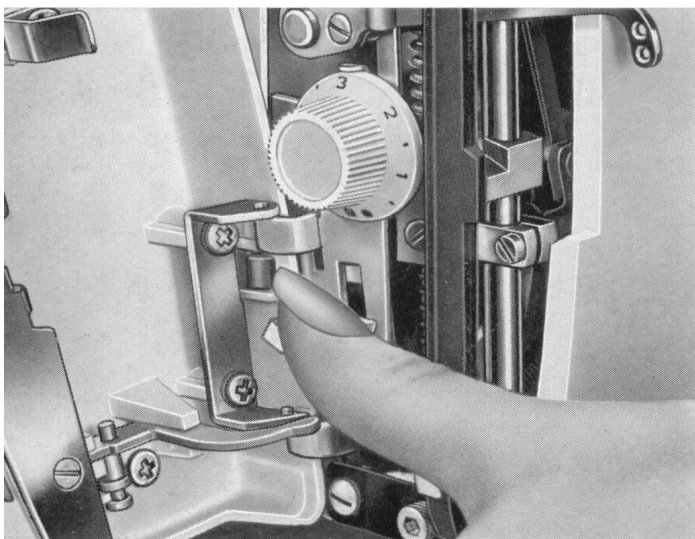

Releasing foot pressure

If you turn the graduated knob for adjustment of presser foot pressure to the black dot located close to the zero position, it is possible to do all mending work by moving the fabric forwards, backwards and sideways by hand.

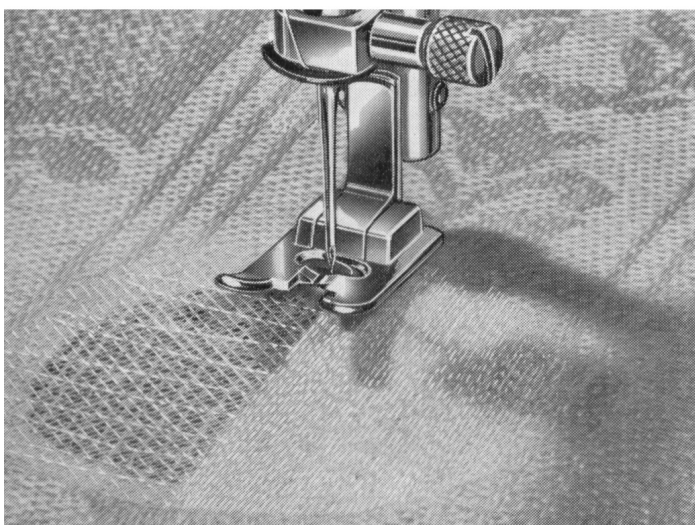

Mending with the ordinary presser foot and released presser foot pressure

The material should preferably be stretched in an embroidery frame. Use tarlatan as mending material for larger holes. Set the machine for straight stitching. After having lowered the feed dog and released the presser foot pressure, you can move the embroidery frame in any direction you choose, back and forth or in circles in order to mend the pattern in a tablecloth, for example.

Do not forget to restore presser foot pressure before using the machine for ordinary sewing.

Darning with darning foot

Change for darning foot 41 12 897. Attachment of the foot is carried out in the same manner as for the other shoes.

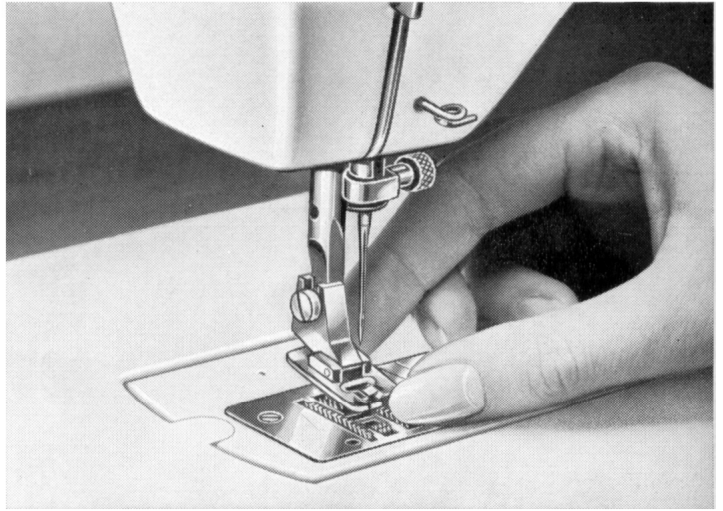
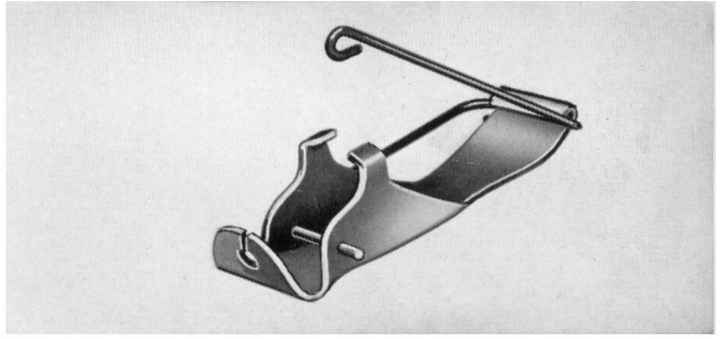

A spring is located on the underside of the presser foot bracket. Insert the darning shoe so that the round transverse pin on the shoe goes in between the bracket and the spring. Then press the shoe lightly downwards and rearwards and it will be correctly positioned.

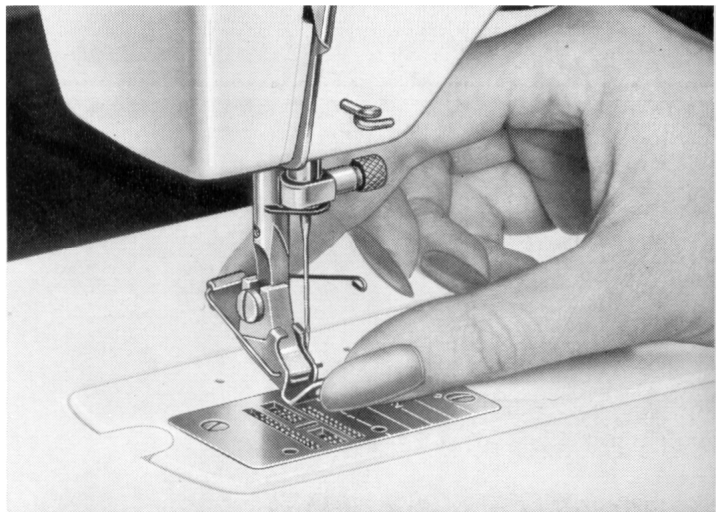

Movement of the presser foot is accomplished by means of a vibrator. It is lifted up when you want to move the fabric but is held down when stitching.

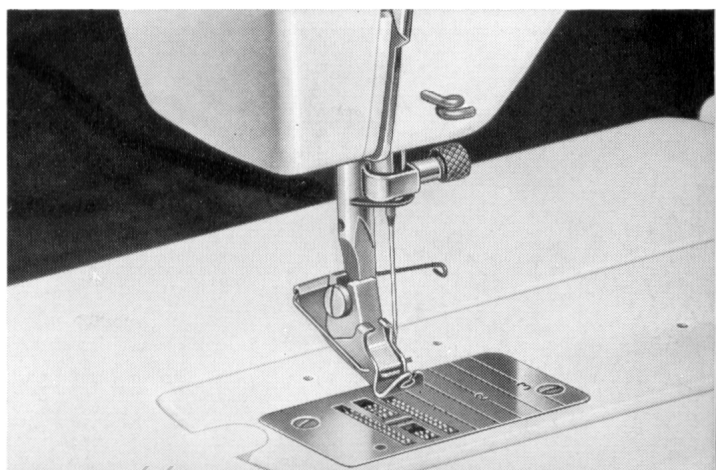

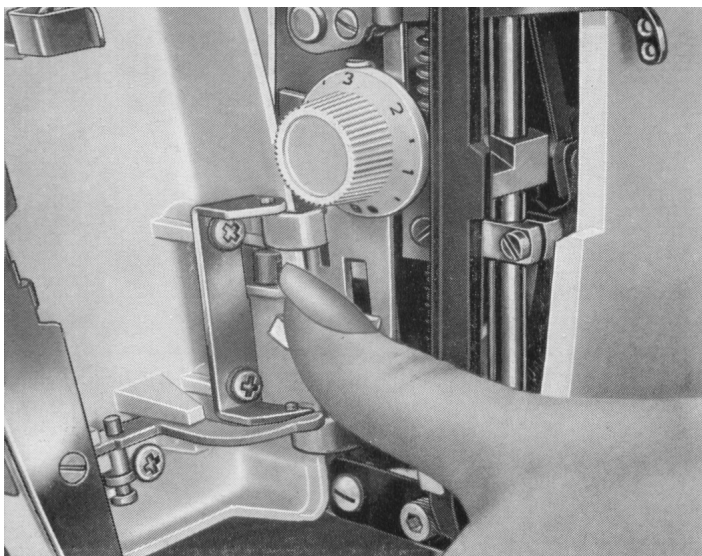

Engage the vibrator by means of the red button located under the face plate (at the left-hand end of the machine).

To disengage presser foot pressure and engage the vibrator, press the red button downwards towards you. Do not forget to disengage the vibrator when you have finished darning.

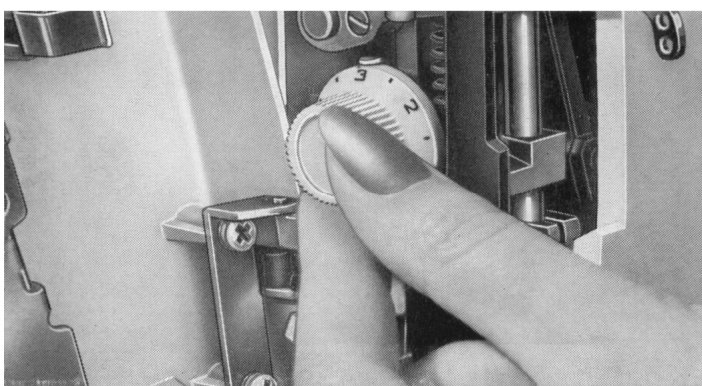

However, if you wish to disengage presser-foot pressure without using the darning shoe — if, for example, you prefer to darn with the ordinary presser foot as described on page 38 under “Presser foot pressure release” — you must turn the graduated knob for adjustment of presser foot pressure to the black dot located close to the zero position.

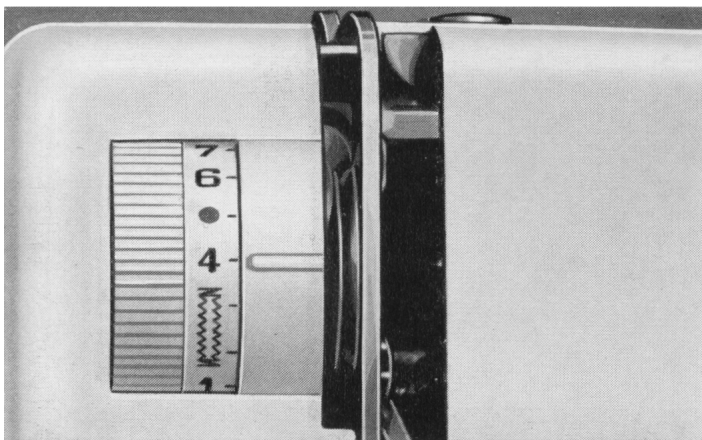

Mending

For mending use darning thread and needle according to table for selecting needle and thread, page 13.

Loosen the tension of upper thread to about 4. Lower the feed dog by pressing the drop feed push-button inwards-downwards, so that the button is held in this position.

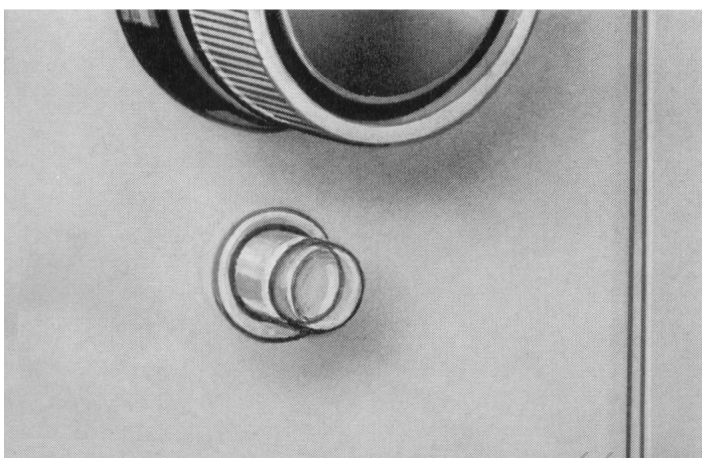

Contents of accessory box

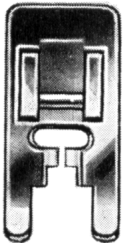

41 12 988
Presser foot for
straight stitching
and zig-zag. Fitted
on the machine.



41 11 385
Hemmer, $\frac{3}{16}$ "
(5 mm), straight and
zig-zag stitching.



41 11 389
Raised seam
presser foot,
three grooves.



41 11 395
Pattern presser
foot.

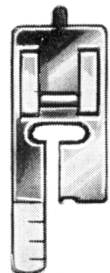

41 11 650
Buttonhole
presser foot.



41 12 897
Darning foot,
with or without
cord insertion.

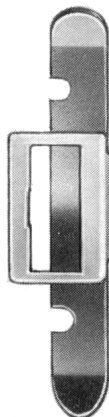

41 12 989
Nähfuß für
Reissverschlüsse.

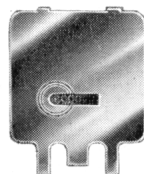

40 15 423
Throat plate for
eyelets, $\frac{9}{64}$ "
(3,5 mm).

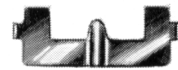

40 15 427
Raised seam
attachment.

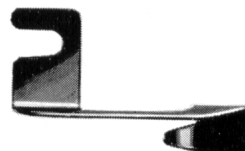

41 12 522
Blindstitching
attachment.

Contents of accessory box

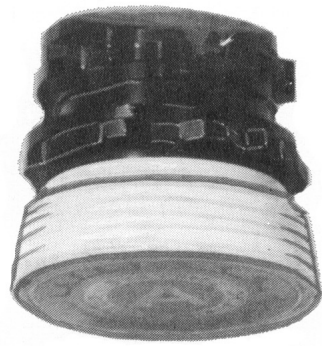
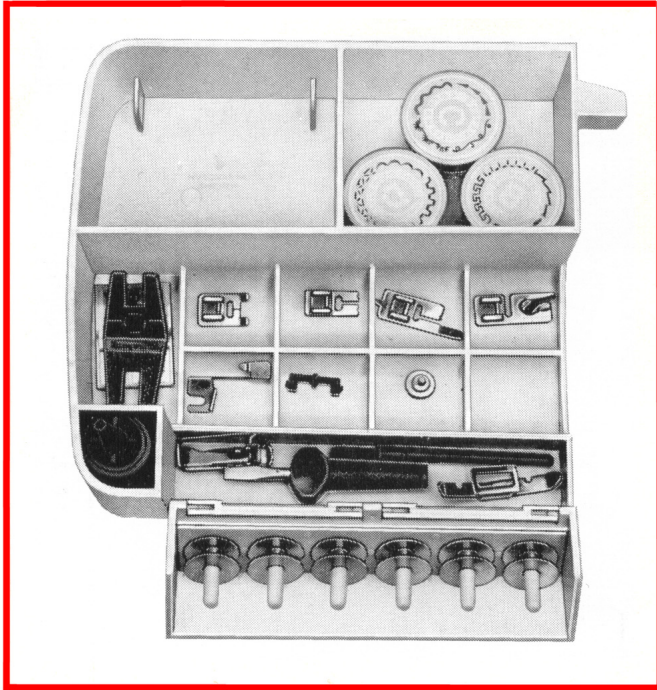

Seam former
 A 41 12 391
 B 41 12 392
 C 41 12 393
 D 41 12 394

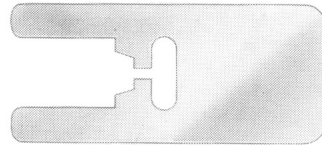

41 11 866-01. Glide plate, teflon.



40 15 399. Buttonhole knife.

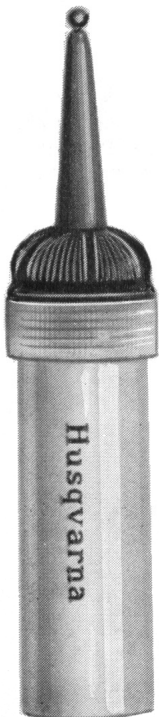
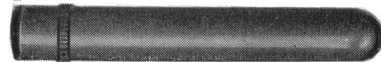

40 10 470
 Oil can.



41 11 732
 Button reed.

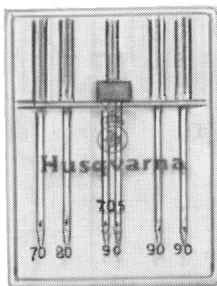

40 15 819
 Needle case with
 needles.



41 12 699. Large screwdriver.



41 12 697. Small screwdriver.



40 15 555. Cleaning brush.



40 15 420. Edge guide.

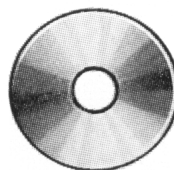

41 12 876
 Bobbins, 6.



41 11 399
 Attachment screw.



Extra accessories

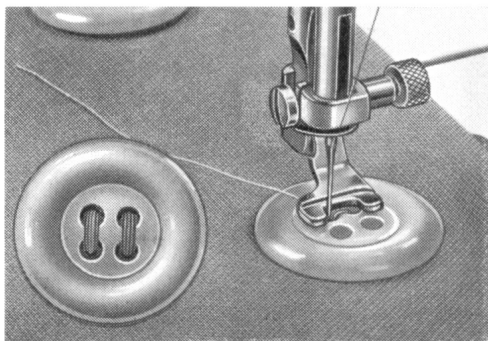

40 15 237. Presser foot for sewing on large buttons and buttons with high edges.

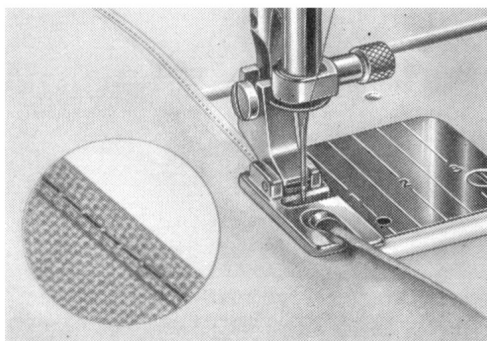

41 11 384. Straight stitch jointed hemmer, $\frac{5}{64}$ " (2 mm).

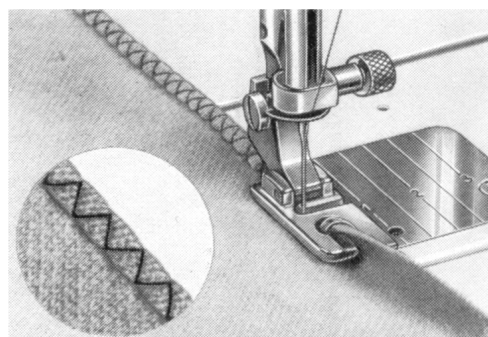

41 11 386. Jointed hemmer for scalloping, $\frac{1}{8}$ " (3 mm), zig-zag and hard tension. Suitable for soft material.

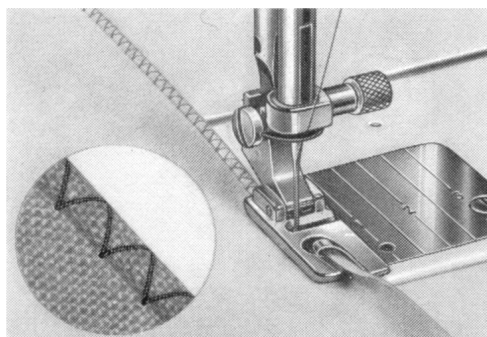

41 11 387. Jointed hemmer for rolled seams, $\frac{5}{64}$ " (2 mm), zig-zag. Suitable for thin material.

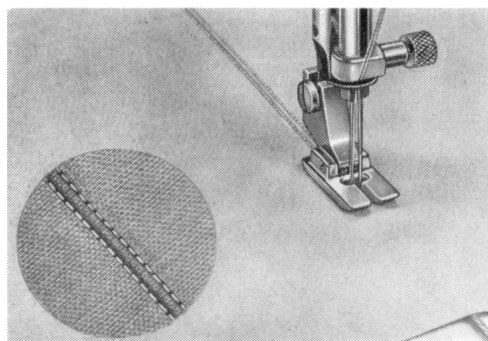

41 11 388. Jointed presser foot, 1 groove, for raised seam, with or without gimp.

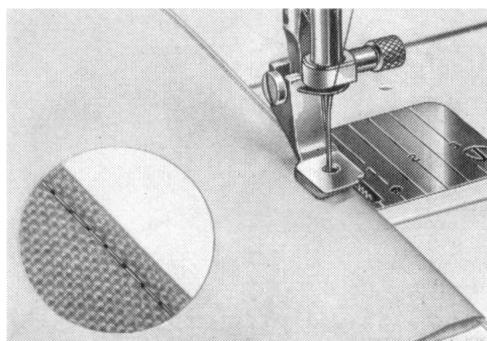

40 93 022. Piping attachment. Insert the cord between the layers of the material.

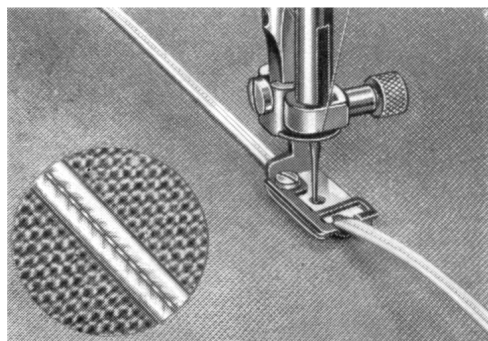

40 93 005. Presser foot for attaching braiding, which is inserted through a guide and attached with a straight stitch in the middle of the braiding.

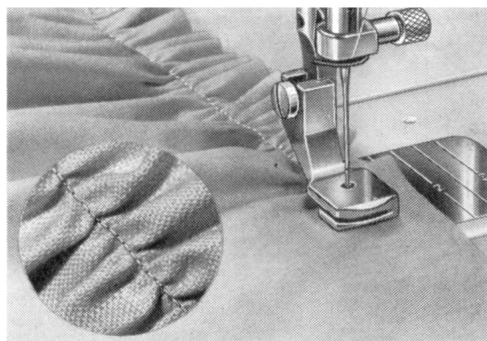

40 93 019. Presser foot for gathering. Gather the material as you sew, the harder thread tension, the stronger gathering.

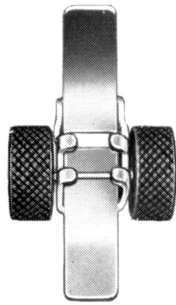

41 12 748
Roller presser foot.

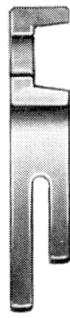

40 23 013
Presser foot,
extra narrow,
for straight
stitching.

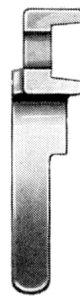

40 13 333
Presser foot for
narrow stitches
and zippers.

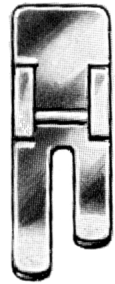

41 11 337
Presser foot for
extra fine straight
stitching in thin
fabrics.

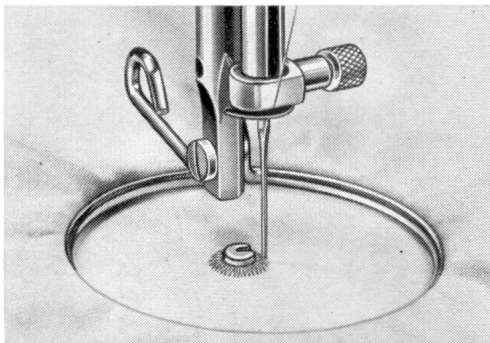

For making closing bars around holes, for example in belts, for cording or as embroidery, the feed dog is covered by a plate. Available for different hole-diameters.

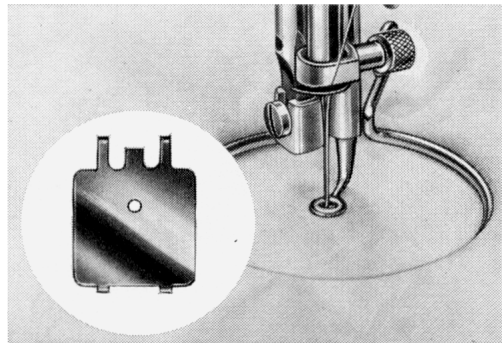

40 15 454. Plate for darning and embroidering with straight stitching especially in thin fabrics. 41 10 586. Presser foot with round needle hole especially for straight stitch darning.

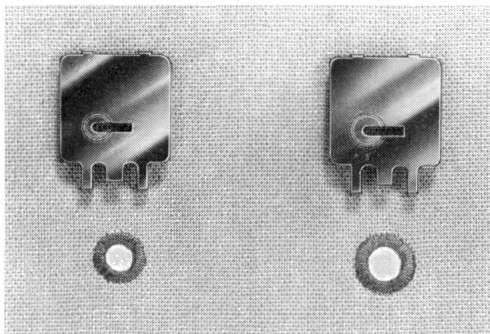

40 13 432. Throat plate for eyelets $\frac{3}{16}$ " (5 mm).
40 15 433. Throat plate for eyelets $\frac{7}{32}$ " (6 mm).

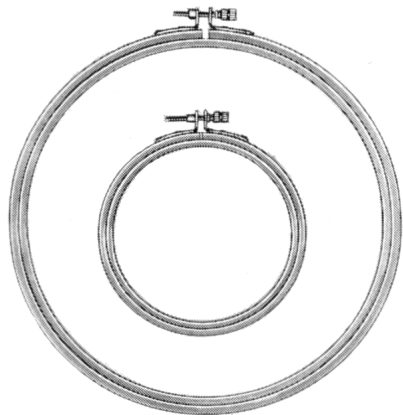

40 93 028. Frame with 8" (20 cm) diameter for darning and embroidery.
40 93 029. Frame with 6" (15 cm) diameter for darning and embroidery.
40 93 030. Frame with 4" (10 cm) diameter for darning and embroidery.

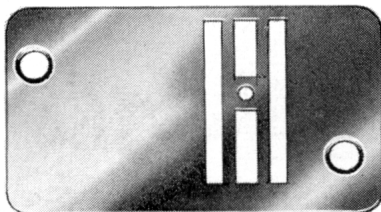

40 15 806
Throat plate
with round
needle hole,
for straight
stitching in
very thin and
loose fabrics.

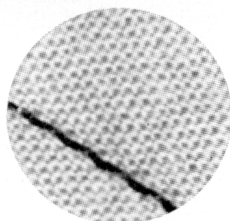

40 15 398. Frame with $\frac{25}{32}$ " (5,5 cm) diameter for darning and embroidery.

41 11 621-03
Twin needle No. 90
with $\frac{5}{64}$ " (2 mm)
needle distance.
41 11 621-01
Twin needle No. 90
with $\frac{1}{8}$ " (3 mm)
needle distance.
41 11 621-02
Twin needle No. 90
with $\frac{5}{32}$ " (4 mm.)
needle distance.
For parallel seams
and twin needle
seams. Max. stitch
width setting for
zig-zag and pattern
stitching 2,5 resp.
1,5 and 0.

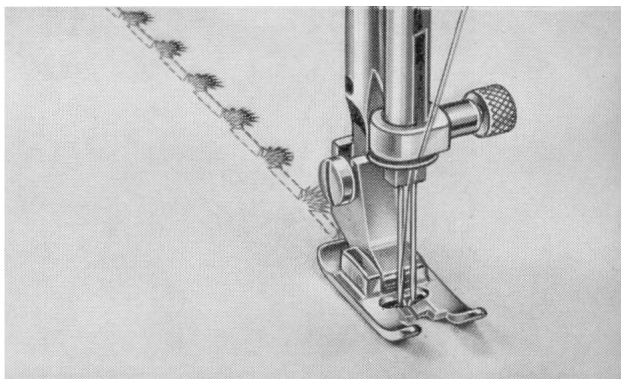
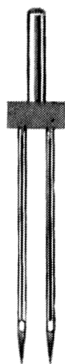

41 11 622-01
Triple needle No. 90
with $\frac{3}{32}$ " (2,5 mm.)
needle distance.
41 11 622-02
Triple needle No. 90
with $\frac{1}{8}$ " (3 mm)
needle distance.
For parallel seams.
Max. stitch width
setting for zig-zag
and pattern stitching
2 resp. 5.
A special spool pin,
40 15 600, can be
used for placing the
three spools.

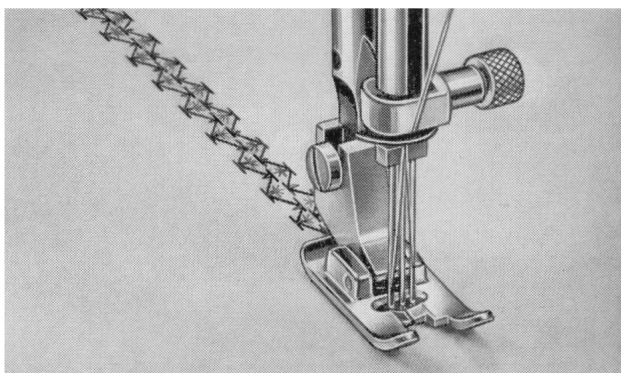

41 12 684
Wing needle pro-
duces a hemstitch-
effect. Can be used
for zig-zag and
pattern stitching.

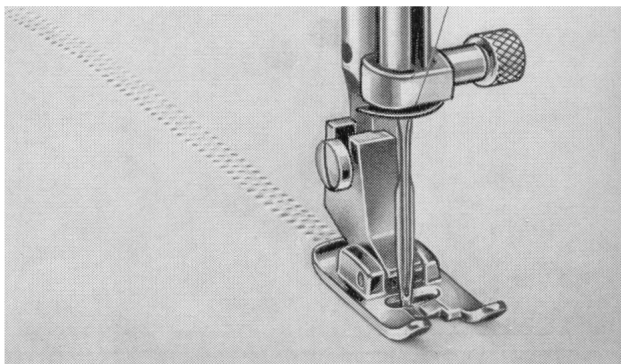

41 12 683
Cutting needle No.
100 for sewing
in leather.

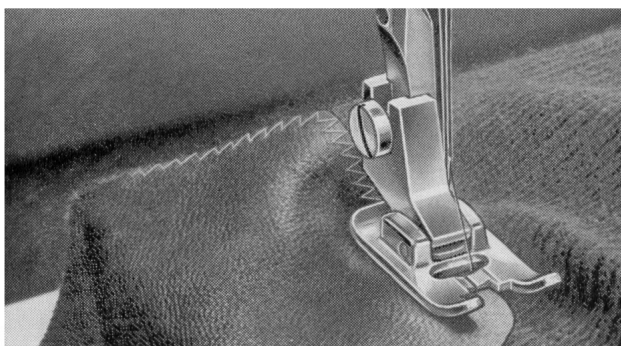

41 12 685-03
No. 100 Slotted
needle for people
with impaired vision.
The needle eye is
supplied with a slot.
When threading,
pass the thread
along the needle,
until the thread
glides into the slot.

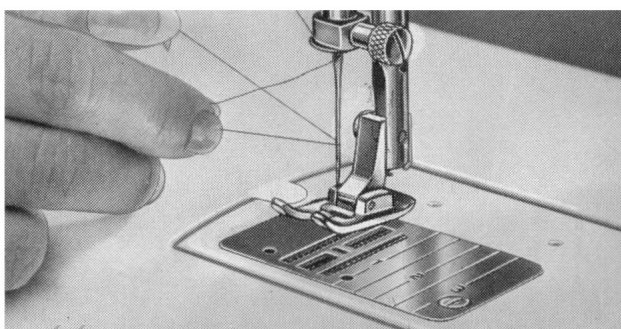

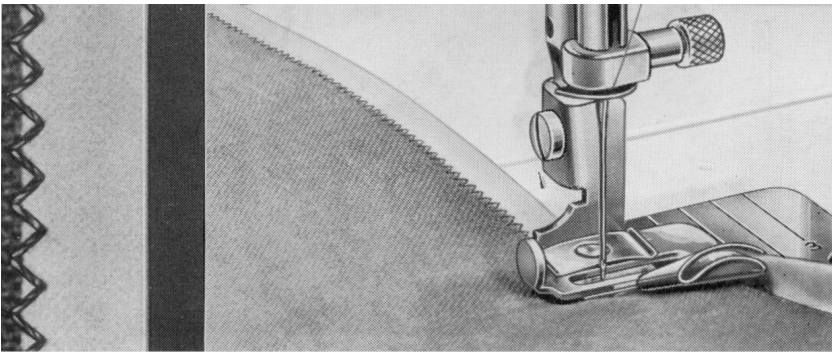

41 11 882
Binder. Can be used for folded as well as unfolded edgings up to a width of $\frac{15}{16}$ " (24 mm).

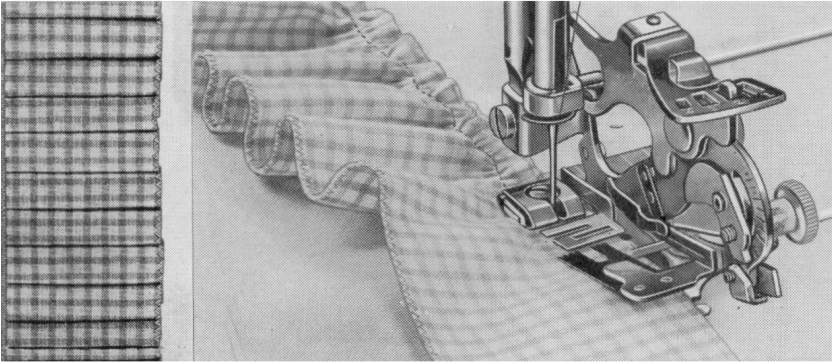

40 93 020
Ruffler. Can be set for gathering or puckering at every, every 6th or every 12th stitch.

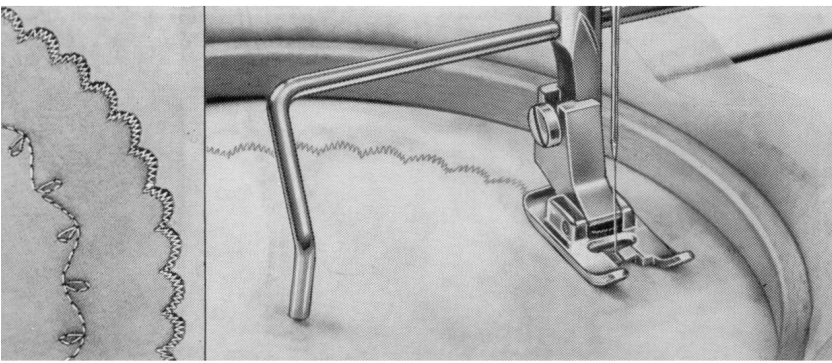

40 15 813
Attachment for circular sewing. Stretch the fabric over an embroidery hoop, place a pin in the middle and attach in the guide.

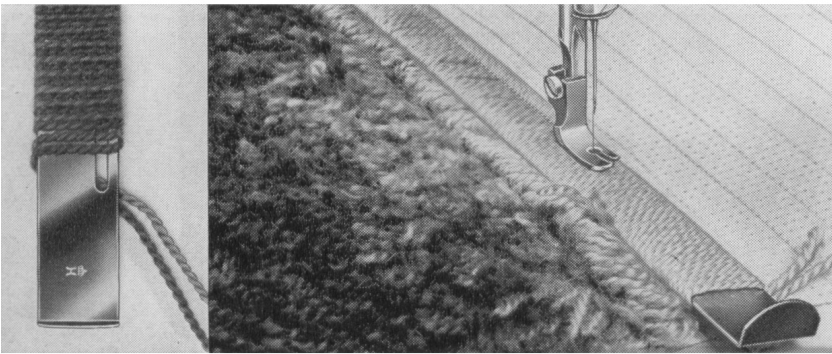

40 99 001
Weaver's reed. Wind the yarn over the reed and sew on with straight stitch. Special presser foot for rug sewing, 40 93 017.

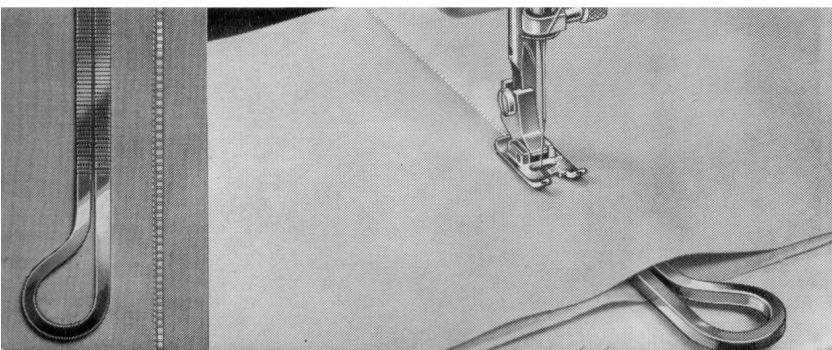

40 15 367
Hemstitcher. Put the fork between two layers of material, which are sewn together with straight stitching and long stitches.



Care of the machine

In order to serve you satisfactorily, your new Husqvarna requires cleaning and oiling like all other precision machines. The arrows in the picture above indicate the oil holes which should be lubricated every week if the machine is used frequently. But even a machine which is not used so often should be lubricated since the oil has a tendency to evaporate.

However, it is important that you do not give the machine too much oil — a few drops at each lubricating point are sufficient. Too much oil does not give better results, the oil only runs out and can stain the fabrics.

The picture shows the lubrication points behind the cover on the left-hand side of the machine (as seen from the front).

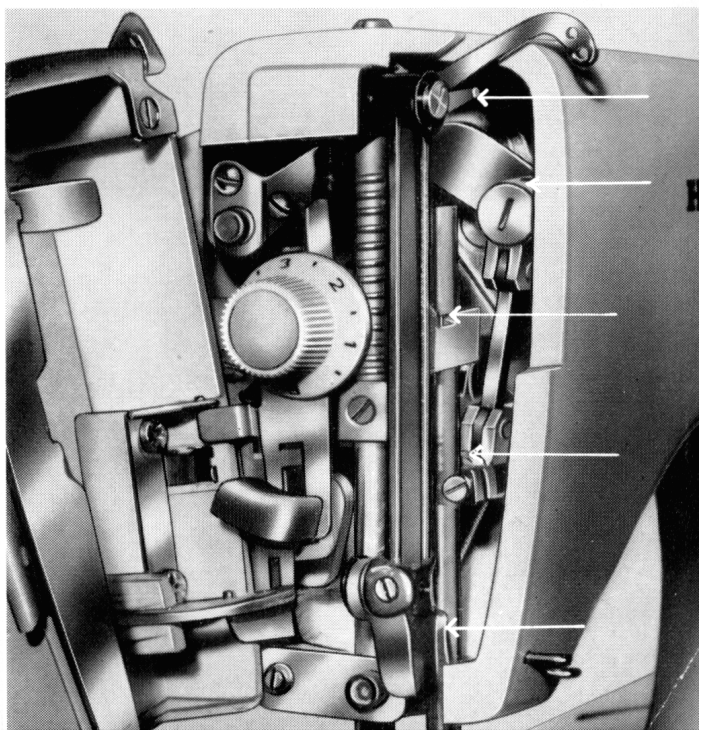

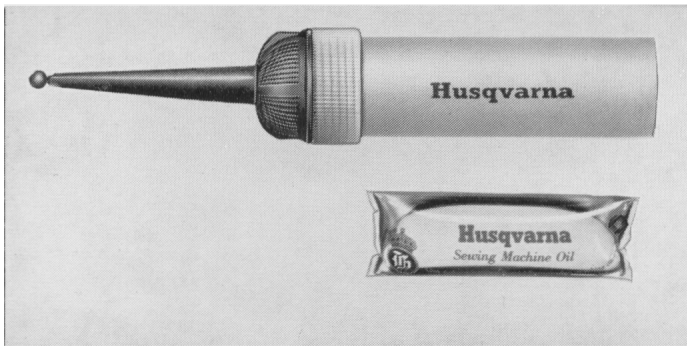

Care of the machine

(continued)

The sewing machine oil is sealed in a plastic packet inside the oiler. Screw off the oiler tube, clip a hole in the packet with scissors, and then screw the oiler tube tightly in place again. To refill the oiler, replace the old oil packet with a new one, or simply fill the oiler in the usual manner.

IMPORTANT. Since oil has a tendency to seep out at screw, threads, etc., the can should not be stored horizontally once the bulb has been opened.

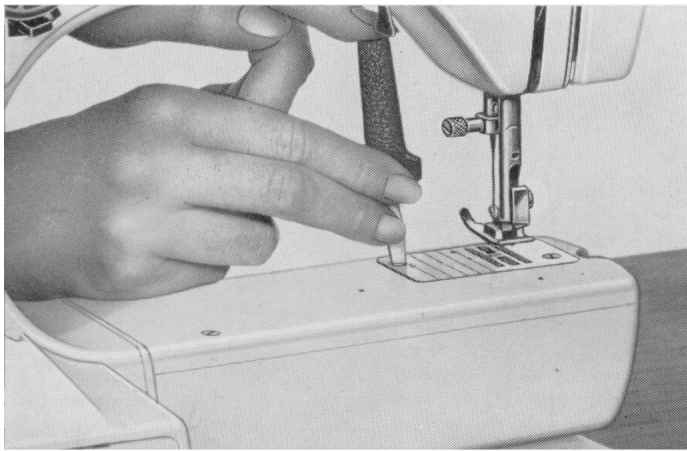

The throat plate should occasionally be removed and the teeth of the feed dog brushed clean.

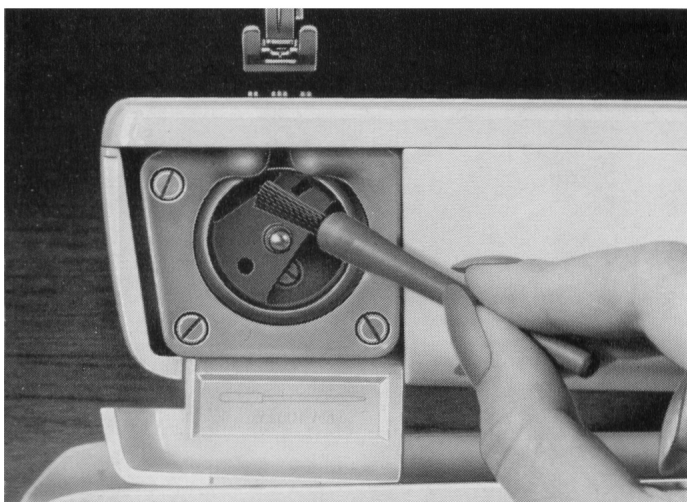

In order to prevent flocking, the bobbin case and shuttle should also be cleaned whenever necessary. This should preferably be done whenever you change the colour of thread and fabric.

Also check that no thread remainders wind around the centre shaft of the shuttle. Possibly the shaft should be wiped clean with a piece of cloth which has been dampened with oil.



Changing the light bulb

A projection to lower the lamp is found on the left side of the lamp guard. Lower the lamp and press it inward at the same time as you turn it counter-clockwise.

When inserting a new lamp bulb, press it into the holder as far as the stop and turn it clockwise.

Fault Finding

In most cases poor sewing results are due to a damaged needle. Therefore always examine the needle first before taking any other action.

Unattractive stitches — unattractive seam

1. The needle is incorrectly inserted. See page 13.
2. The needle is bent or blunt. Change the needle.
3. The thread tension is not correct. See page 14.
4. The machine may be incorrectly threaded. Correct threading, see page 7—8.
5. The needle, thread and fabric do not correspond. See table on page 13.
6. Incorrect lower thread. It should be of the same thickness as the upper thread.
7. Lower thread unevenly wound. See pages 5—6.
8. Bobbin incorrectly inserted in bobbin case. See page 6.

Lower thread not brought up by the upper thread

Needle incorrectly inserted. See page 13.

Needle breaks

1. The throat plate is too loose. Tighten the throat plate with the larger screwdriver. See page 50.
2. You may have helped the machine to feed through the fabric by pulling it. The needle can then easily come against the throat plate and be broken.

Upper thread breaks

1. The needle is bent or blunt.
2. The needle is incorrectly inserted. See page 13.
3. The upper thread is incorrectly threaded. Correct threading on pages 7—8.
4. The upper thread may be too tightly tensioned. See thread tension on page 14.
5. Knots in the thread.
6. The needle and thread do not correspond. See needle and thread table on page 13.
7. The hole in the throat plate may be chipped and have sharp edges. Polish with an emery cloth or change the throat plate. See page 46.
8. The needle groove or needle eye may have sharp edges. Change needle. See page 13.

Lower thread breaks

1. Bobbin case incorrectly inserted. See page 5.
2. Lower thread may be incorrectly threaded. See page 6.
3. Lower thread too tightly tensioned. Pages 15—16 show how to correct this fault.
4. Bobbin unevenly wound. See page 5.
5. Bobbin wound too full. See page 5.

6. Throat plate hole damaged. Polish it with an emery cloth or change the throat plate. See page 50.

Machine does not feed the fabric

1. The stitch length knob is set on 0.
2. The feed dog may be lowered. Raise it by pressing the feed dog lowering button inward and upward. See page 33.
3. Presser foot pressure may be released. See page 40.

Irregular bobbin winding

1. The bobbin is not pressed in far enough. See page 6.
2. The machine is not correctly threaded for bobbin winding. See page 5.
3. The thread guides for bobbin winding is not correctly adjusted. See page 6.

Uneven thread tension

1. This may be due to poor thread quality.

Fabric puckers

1. The upper thread is too tightly tensioned. Correct upper thread tension is illustrated on page 14.
2. Upper and lower thread tension too tight in relation to the thickness of the fabric. See page 14.

Stitch length varies

The feed dog is choked by dust and dirt. Clean it with the special brush. See page 46. The presser foot pressure is released.

The seam is too loose — fabric layers not held together

The thread tension is too slack. The adjustment of the thread tension is illustrated on page 14.

Machine does not sew the stitch indicated

Seam former incorrectly inserted. Directions on page 27.

Machine runs sluggishly

1. Dirt or lint have got under the throat plate. Loosen the throat plate and brush clean between the teeth of the feed dog.
2. Dirt or lint have got into the shuttle. Take out the bobbin and bobbin case and brush clean with special brush.
3. This may also be because the machine has not been lubricated for a long time. See the chapter on lubrication on page 50. If the wrong type of oil was previously used, consult your local Husqvarna representative.

Machine is noisy

In most cases this is due to poor lubrication. See lubrication instructions on page 50.

This page is intentionally blank

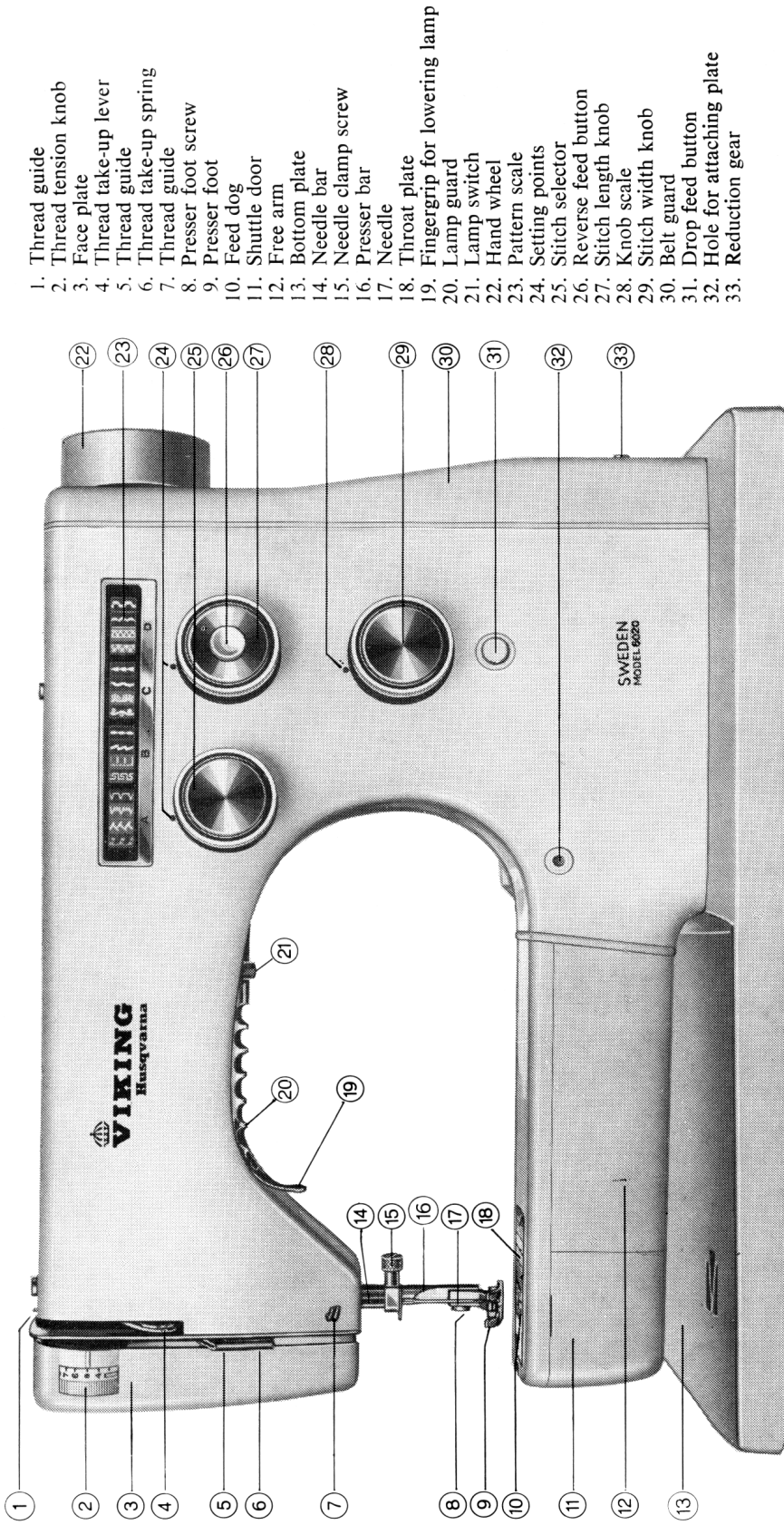

1. Thread guide
2. Thread tension knob
3. Face plate
4. Thread take-up lever
5. Thread guide
6. Thread take-up spring
7. Thread guide
8. Presser foot screw
9. Presser foot
10. Feed dog
11. Shuttle door
12. Free arm
13. Bottom plate
14. Needle bar
15. Needle clamp screw
16. Presser bar
17. Needle
18. Throat plate
19. Fingergrip for lowering lamp
20. Lamp guard
21. Lamp switch
22. Hand wheel
23. Pattern scale
24. Setting points
25. Stitch selector
26. Reverse feed button
27. Stitch length knob
28. Knob scale
29. Stitch width knob
30. Belt guard
31. Drop feed button
32. Hole for attaching plate
33. Reduction gear



**HUSQVARNA VAPENFABRIKS AKTIEBOLAG
HUSKVARNA . SWEDEN**